

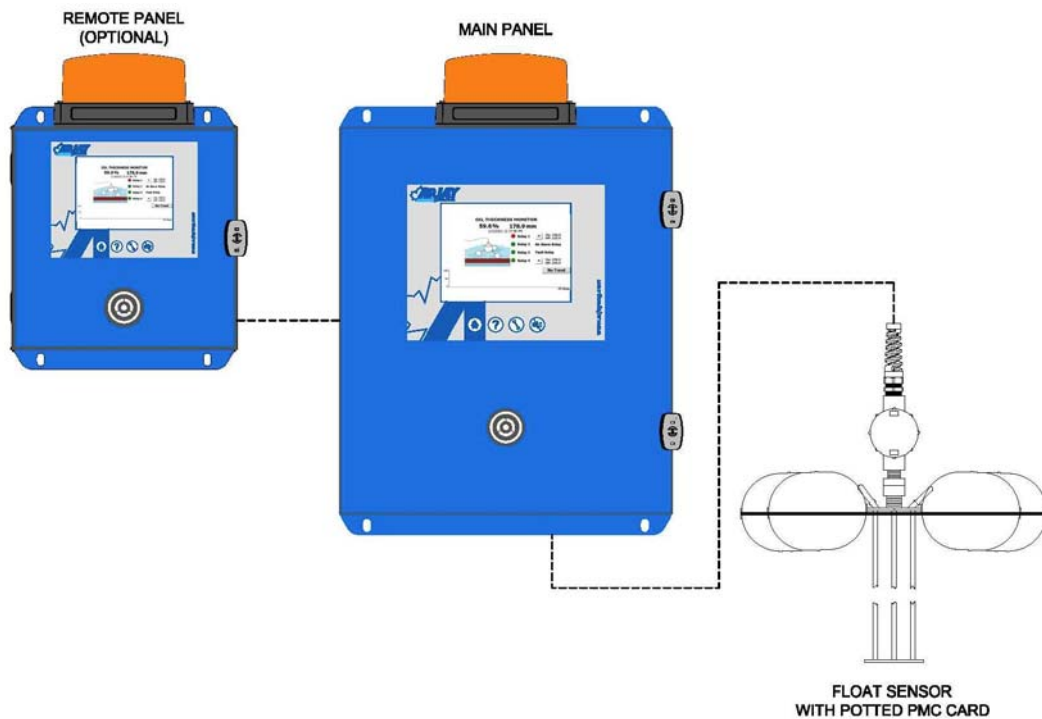

**MODELS:**

**4100-HCF2**

**FLOATING OIL THICKNESS MONITOR**



**USER MANUAL (REV: 3.0)**

<b>ARJAY ENGINEERING</b>		
2851 Brighton Road Oakville (Toronto), Canada L6H 6C9	TEL: ++1 (905) 829-2418 FAX: ++1 (905) 829-4701 NORTH AMERICA: 1-800-387-9487	WEBSITE: <a href="http://www.arjayeng.com">www.arjayeng.com</a> EMAIL: <a href="mailto:arjay@arjayeng.com">arjay@arjayeng.com</a>

**THIS PAGE INTENTIONALLY LEFT BLANK**

# TABLE OF CONTENT

## NOTICE

*Please* read the Installation Notes (4.0) prior to locating and mounting the instrument.

<b>1.0</b>	<b>SPECIFICATION .....</b>	<b>5</b>
<b>2.0</b>	<b>USE HAZARD INFORMATION.....</b>	<b>7</b>
<b>3.0</b>	<b>INSTRUMENT OVERVIEW.....</b>	<b>8</b>
3.1	Features .....	10
3.2	Model Number Table .....	10
<b>4.0</b>	<b>INSTALLATION.....</b>	<b>11</b>
4.1	Main and Remote Panel Installation .....	11
4.2	Sensor Installation .....	12
<b>5.0</b>	<b>ELECTRICAL INSTALLATION OVERVIEW .....</b>	<b>14</b>
5.1	Permanent Power Connection (AC Powered Models Only) .....	15
5.2	Glossary Of Symbols.....	15
<b>6.0</b>	<b>STARTUP .....</b>	<b>16</b>
6.1	Startup .....	16
6.2	Screen Menu Background Information .....	16
6.2.1	Keypad Main Menu Entry .....	17
6.2.2	Password.....	18
<b>7.0</b>	<b>CONTROLLER NETWORK.....</b>	<b>19</b>
7.1	Configure Main Screen View .....	19
7.2	Alarms Setup .....	20
7.3	Date and Time .....	22
7.4	Analog (mA) Output (Optional) .....	23
7.5	mA Output Trim (Optional) .....	23
7.6	Buzzer and Strobe Beacon (Optional).....	23
7.7	Level Sensor mA Input (Optional) .....	23
7.8	Calibration .....	24
7.8.1	Quick Calibration .....	25
7.8.2	Full Calibration.....	26
7.8.3	Manual Calibration.....	26
7.9	Diagnostic Information.....	27
<b>8.0</b>	<b>TROUBLESHOOTING.....</b>	<b>29</b>
<b>9.0</b>	<b>CONTROLLER SETTING SHEET .....</b>	<b>31</b>
<b>10.0</b>	<b>MODBUS MAP AND DETAIL (OPTIONAL).....</b>	<b>34</b>
10.1	Modbus Commands Supports .....	34
10.2	Register Map .....	34
<b>11.0</b>	<b>DETAIL ELECTRICAL AND DIMENSIONAL DRAWINGS.....</b>	<b>35</b>

## TABLE OF FIGURES

FIGURE 1 – INSTRUMENT SYSTEM OVERVIEW .....	8
FIGURE 2 – FLOAT SENSOR INSTALLATION OVERVIEW .....	12
FIGURE 3 – TYPICAL OIL THICKNESS MONITOR APPLICATION OVERVIEW .....	13
FIGURE 4 – ELECTRICAL INSTALLATION OVERVIEW .....	14
FIGURE 5 – MAIN SCREEN VIEW .....	16
FIGURE 6 – PASSWORD SCREEN VIEW .....	18
FIGURE 7 – PARAMETER SETTINGS SCREEN VIEW .....	19
FIGURE 8 – CONFIGURE MAIN SCREEN VIEW.....	19
FIGURE 9 – ALARM SETTING SCREEN VIEW (DISABLED RELAY 3 & 4) .....	20
FIGURE 10 – ALARM SETUP SCREEN VIEW .....	21
FIGURE 11 – DATE AND TIME SCREEN VIEW.....	22
FIGURE 12 – ANALOG OUTPUT SCREEN VIEW .....	23
FIGURE 13 – BUZZER & STROBE SETTING SCREEN VIEW .....	24
FIGURE 14 – PULSE CARD SET-UP SCREEN VIEW .....	24
FIGURE 15 – CALIBRATION REMINDER SCREEN VIEW.....	25
FIGURE 16 – QUICK CALIBRATION SET-UP SCREEN VIEW.....	25
FIGURE 17 – FULL CALIBRATION SET-UP SCREEN VIEW.....	26
FIGURE 18 – MANUAL CALIBRATION SET-UP SCREEN VIEW .....	26
FIGURE 19 – DIAGNOSTIC INFORMATION SCREEN VIEW.....	27

## 1.0 SPECIFICATION



Specifications are subject to change without notice

<b>Specification</b>	<b>Details</b>
<b>Power Input:</b> (Specify voltage at time of Order)	100VAC – 240VAC +/- 10%, 50/60 Hz, (1.22A → 0.66A) 1.6A Fuse 24VDC, 2.5A maximum (Optional) <b>Note:</b> DC input models must be supplied by Limited Energy power source. Limited Energy means compliance with one of the following requirements: <ul style="list-style-type: none"> <li>- Class 2 circuit according to Canadian Electrical Code, Part, I, C22.1;</li> <li>- Class 2 circuit according to National Electrical Code, NFPA-70;</li> <li>- Limited Power Supply (LPS) according to IEC 60950-1;</li> <li>- Limited-energy circuit according to IEC 61010-1.</li> </ul>
Connections to mains supply	Permanent (for AC/DC model)
<b>User Interface:</b> Touch Screen	Full Colour 7" display on Main Panel Monochrome 4" on Remote Panel
<b>Relays / Analog Outputs:</b> Alarm Relay Outputs (R1, R2, R3 & R4**) **Can be selected as pump relay or Level Alarm)	DPDT relay, 8A @ 250 VAC dry contacts Selectable failsafe or non-failsafe Programmable time delay: 0 – 60 minutes ON and OFF R1 relay for setpoint Oil alarm, R2 relay for setpoint Air (Dry condition) alarm *, R3 relay for system fault alarm * * these relays can be selected for Oil alarm R4 relay for setpoint Oil alarm**
Option: Pump Relay or Level Alarm (R4)	DPDT relay, 8 A @ 250 VAC dry contacts Programmable pump run time <b>OR</b> can be set as a level alarm from external level sensor
mA Signal Output	0/4-20mA non-isolated, 600 ohms Self powered
Communication (Optional)	RS-485 Modbus
<b>Float Sensor Input:</b>	Capacitance Sensor with PMC input
<b>External Level Sensor Input:</b>	4-20mA input from Level transmitter
<b>Instrument Performance:</b>	
Accuracy	0.04% of full scale pF
Resolution	0.007% (0.07pF at 1000pF)

<b>Environmental:</b>	
Operating conditions	Continuous
Ambient Temperature	0°C to +55 °C controller 0 to +55 °C Float Sensor with potted PMC (Optional high temperature sensor available. Consult factory)
Relative humidity	0 to 95% (non-condensing)
Installation Category	II
Pollution Degree	2
Equipment mobility	Fixed
<b>Mechanical Specification:</b>	Refer to Dimensional Drawing

## 2.0 USE HAZARD INFORMATION

---

 <b>CAUTION</b>	Indicates a potentially hazardous situation that may result in minor or moderate injury.
 <b>WARNING</b>	Indicates a potentially or imminently hazardous situation which, if not avoided, could result in death or serious injury.
 <b>DANGER</b>	Indicates a potentially or imminently hazardous situation which, if not avoided, will result in death or serious injury.
<b>NOTICE</b>	Indicates a situation which, if not avoided, may cause damage to the instrument. Information that requires special emphasis.

### 3.0 INSTRUMENT OVERVIEW

The Arjay Model 4100-HCF is a capacitance based interface monitor used for the measurement and control of separated oil on a water surface.

The main panel receives an input from the Arjay PMC card which is potted within the floating sensor. Through a site calibration, the unit displays the oil depth on water and provides proportional outputs and relay controls. As an option there is a display of level from an external level sensor.

The monitoring system is comprised of one main control panel, floating sensor with potted PMC card.

Optional Remote alarm panels can also be added that will display and provide audio/visual alarms

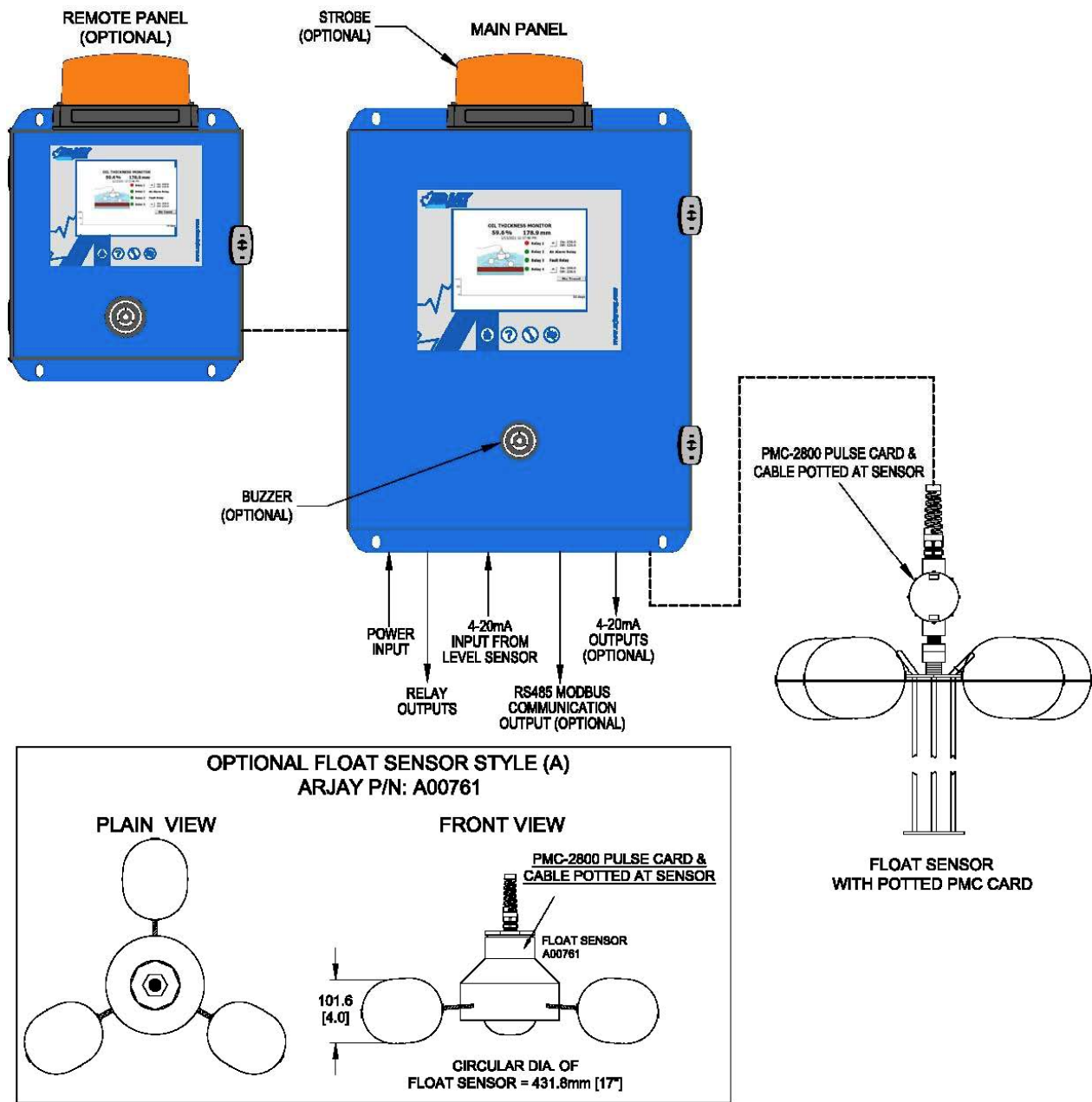

Figure 1 – Instrument System Overview



## **Main Panel**

The main panel is a wall mounted touch screen monitor to be installed in a general purpose (non-hazardous) location that is accessible for set-up and observation of the display and alarms.

Four relays are available. Relay 1 can be field set to alarm at any depth of oil within the range of the sensor. Relay 2 is factory set as an Air alarm (Dry condition). Relay 3 is factory set as a system fault relay. Relay 4 can be set as a (1) general purpose oil alarm (factory default), (2) Pump Run relay with a timed and auto shut-off feature or (3) level sensor mA input alarm. Relay 2 and 3 can also be selected to act as Oil Alarm relays. See section 7.2 for instruction to change alarm setup.

A 4-20 mA non-isolated output and Modbus RS-485 are optional. The power input at the main panel serves the HMI, PLC, and sensor requirements.

An optional Buzzer and strobe (beacon) are available.

The float may be made Intrinsically Safe for Hazardous Classified locations through the installation of an IS Barrier in the main panel.

The main panel screen provides additional user interface menus for diagnostics, analog output, calibration, set-up and general help information. Diagnostic Menus can be accessed for viewing at any time but a passcode entry is required to make setup changes.

## **Remote Panel**

Remote panels are available to mimic the screen and audio/visual alarms of the main panel. All access to the touch screen menus are password protected on the remote panels.

## **Sensing float**

An Arjay PMC card is potted within the sensor. This converts the capacitance reading of the oil thickness into a frequency pulse for transmission to the main panel. This unique approach eliminates any operator interface requirements at the sensor. All diagnostics and calibration is done at the main panel.

The sensor floats on the surface of the changing water level and is tuned to the capacitance field below it. When oil separates to the surface, the capacitance reading decreases.

The premise of this stable and reliable technology is that the sensor is continuously floating. In applications where the well or sump may go dry, the water is displaced with air rather than oil. This will indicate as an oil condition until the water has lowered enough to initiate the Air alarm. In such applications, a separate low level switch may be considered to alert operations or lock out an oil alarm that is caused by air displacing the water rather than oil.

## **External Level Sensor input**

A display of the overall level of the sump or tank is provided as an option. This would require a 4-20mA input from an external level sensor. Relay 4 can be enabled as a level sensor alarm.

### 3.1 Features

- Touch Screen Interface with passcode protection
- Microprocessor based Controller
- Oil Display in % and engineering units
- Diagnostic, set-up and Help menus on all screens
- Four alarm relays
- Optional analog outputs and RS-485 communication
- Optional level display in % and unit of measurement

### 3.2 Model Number Table

<b>4100-HCF2</b>	-	<b>a</b>	-	<b>b</b>	<b>c</b>	<b>d</b>	<b>e</b>	<b>f</b>	<b>g</b>	-	<b>h</b>
		<b>a - Power Input</b>		<b>b - Enclosure</b>				<b>h - Custom vs. Standard</b>			
		1 - 100-240 VAC 2 - n/a 3 - n/a 4 - 24 VDC		0 - No 1 - Type 4/IP65 Steel 2 - Type 4X/IP65 Poly 3 - Type 4X/IP65 SS 9 - Custom				x - Custom** z - Standard **Fill in the custom requirement below.			
				<b>c - Strobe Beacon</b>							
				0 - No 1 - Yes							
				<b>d - Buzzer</b>							
				0 - No 1 - Yes							
				<b>e - 4-20mA Output</b>							
				0 - No 1 - Yes							
				<b>f - RS-485 Modbus Communication</b>							
				0 - No 1 - Yes							
				<b>g - Intrinsic Barrier</b>							
				0 - No 1 - Yes							
<b>x - Custom Description</b>											

Example:

<b>4100-HCF2</b>	-	<b>1</b>	-	<b>1</b>	<b>1</b>	<b>1</b>	<b>0</b>	<b>0</b>	<b>0</b>	-	<b>z</b>
		↓		↓	↓	↓	↓	↓	↓		↓
		100-240 vac Power Input Selected		Steel Enclosure Selected	Strobe Selected	Buzzer Selected	No 4-20mA Selected	No RS-485 Selected	No Intrinsic Barrier Selected		Standard Configuration Selected

## 4.0 INSTALLATION

---

<b>NOTICE</b>	<b>If any damage to the instrument is found, please notify an Arjay Engineering representative as soon as possible prior to installation.</b>
<b>NOTICE</b>	<b>Qualified Personnel must undertake all installations.</b>

 <b>WARNING</b>	<b>If the equipment is used in a manner not specified by the manufacturer, the protection provided by the equipment may be impaired.</b>
--	--

### 4.1 Main and Remote Panel Installation

Choose the mounting location in accordance with good instrument practice. Extremes of ambient temperature and vibration should be avoided (see specifications and installation drawing).

Remote mimic panels can be mounted up to 300 meters away from the main panel.

The float sensor with built-in PMC card can be mounted up to 1 km away from the main panel.

<b>NOTICE</b>	<b>The controller operates in a Failsafe Mode (factory default).</b>
---------------	--

This means that the relays are in an energized state during normal operation. The N.O. relay contact will be held closed and the N.C. relay contact will be held open during a normal condition. This will allow the relay to return to its non-energized (shelf) state during an alarm, fault or power failure condition. If using the Relay 4 as Pump Run relay then non-failsafe mode is used. Wire accordingly.

 <b>CAUTION</b>	<b>The <u>Internal</u> ground screw provided in this enclosure must be used for equipment grounding connection.</b> <b>The <u>External</u> ground screw is provided for use only as a supplemental connection where required (or, permitted) by local codes or authorities.</b>
--	--

## 4.2 Sensor Installation

### NOTICE

Read the following information ***before*** installation.

The floating sensor comes with 30meter (100ft) of 3 conductor cable. Any excess cable should be cut back. The installation must allow enough cable for the float sensor to extend down to the lowest water level.

When the float sensor (A00765) is floating in water the complete white Teflon probe should be submerged. There is a 1" diameter wire guide available on the float if the user decides to install a guiding rod/wire in sump.

When the float sensor (A00761) is floating the bottom of sensing pod should be submerged up to "Water Line" indication.

As the float rises, the cable will hang into the water. A minimal water level change of less than 2 meters is recommended to reduce the stress pull on the sensor. The sensor should be placed in an area of calm or protected water. Any splitter junction box must be mounted above the flood level and sealed from condensation in the conduit.

In applications of high turbulence and extremes of level change, additional guide restraints may be required. Consult Arjay Engineering.

### NOTICE

To ensure proper operation and electrical safety, make sure the controller is electrically grounded.

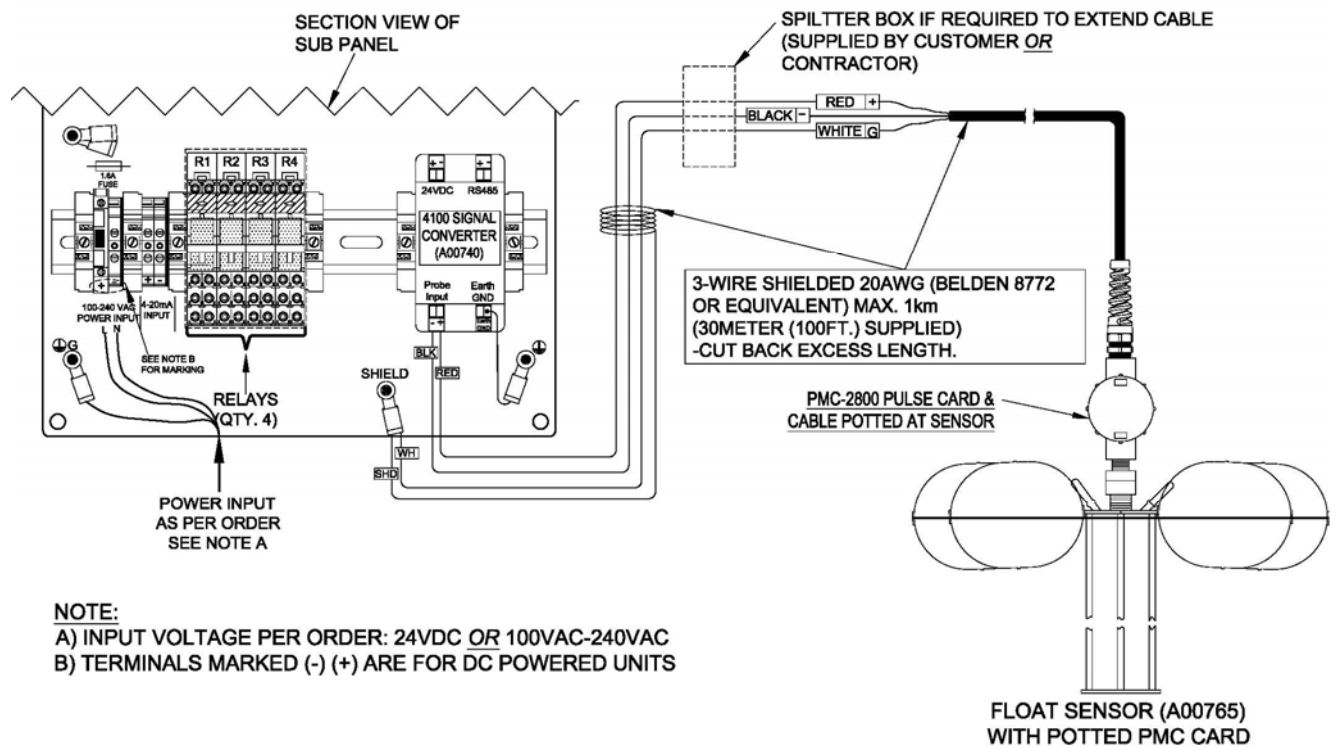

**Figure 2 – Float Sensor Installation Overview**  
(Without Intrinsic Safety Barrier)

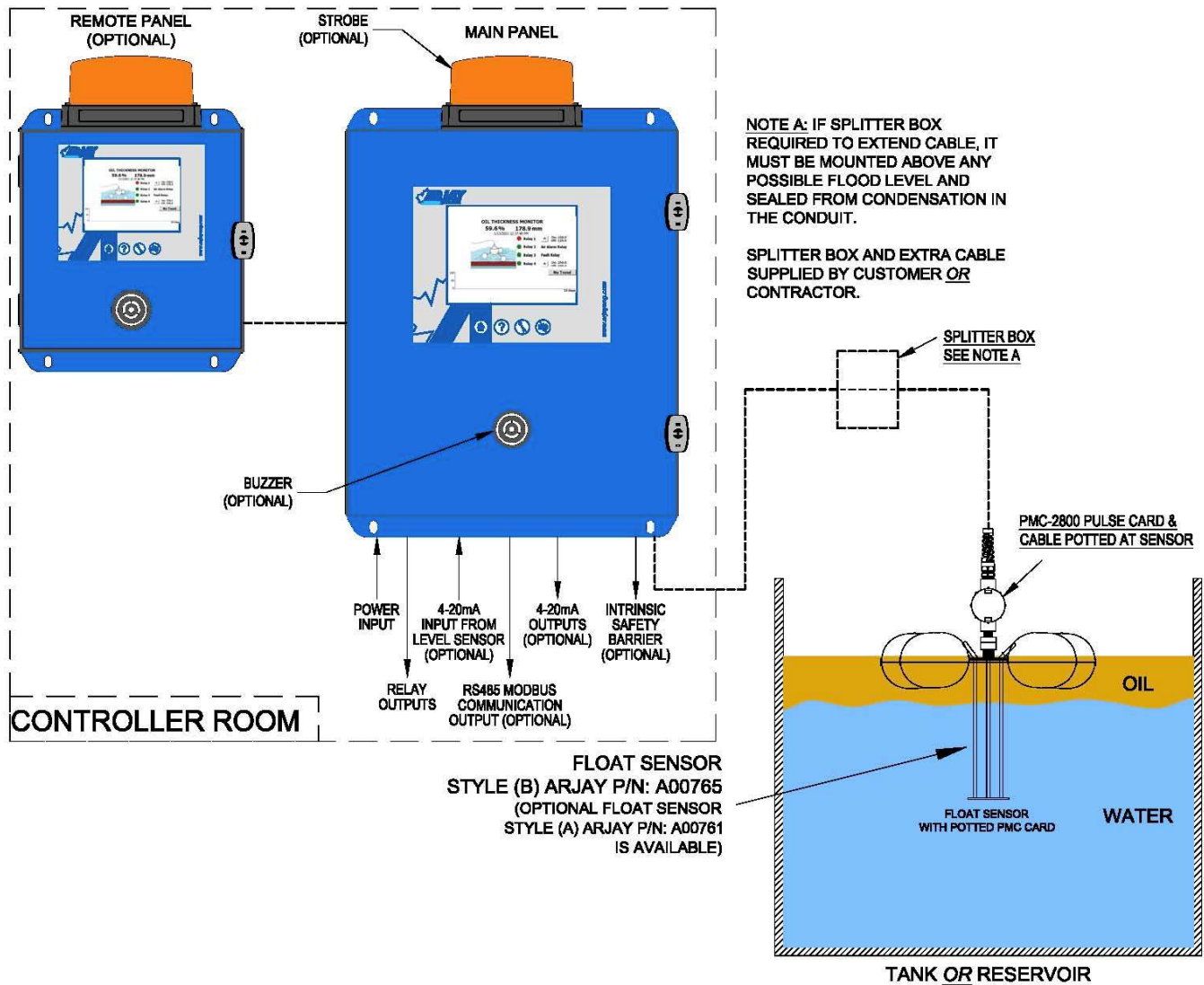

**Figure 3 – Typical Oil Thickness Monitor Application Overview**

## 5.0 ELECTRICAL INSTALLATION OVERVIEW

Refer to the drawings provided by the contractual engineer for your project and the drawings included with this manual.

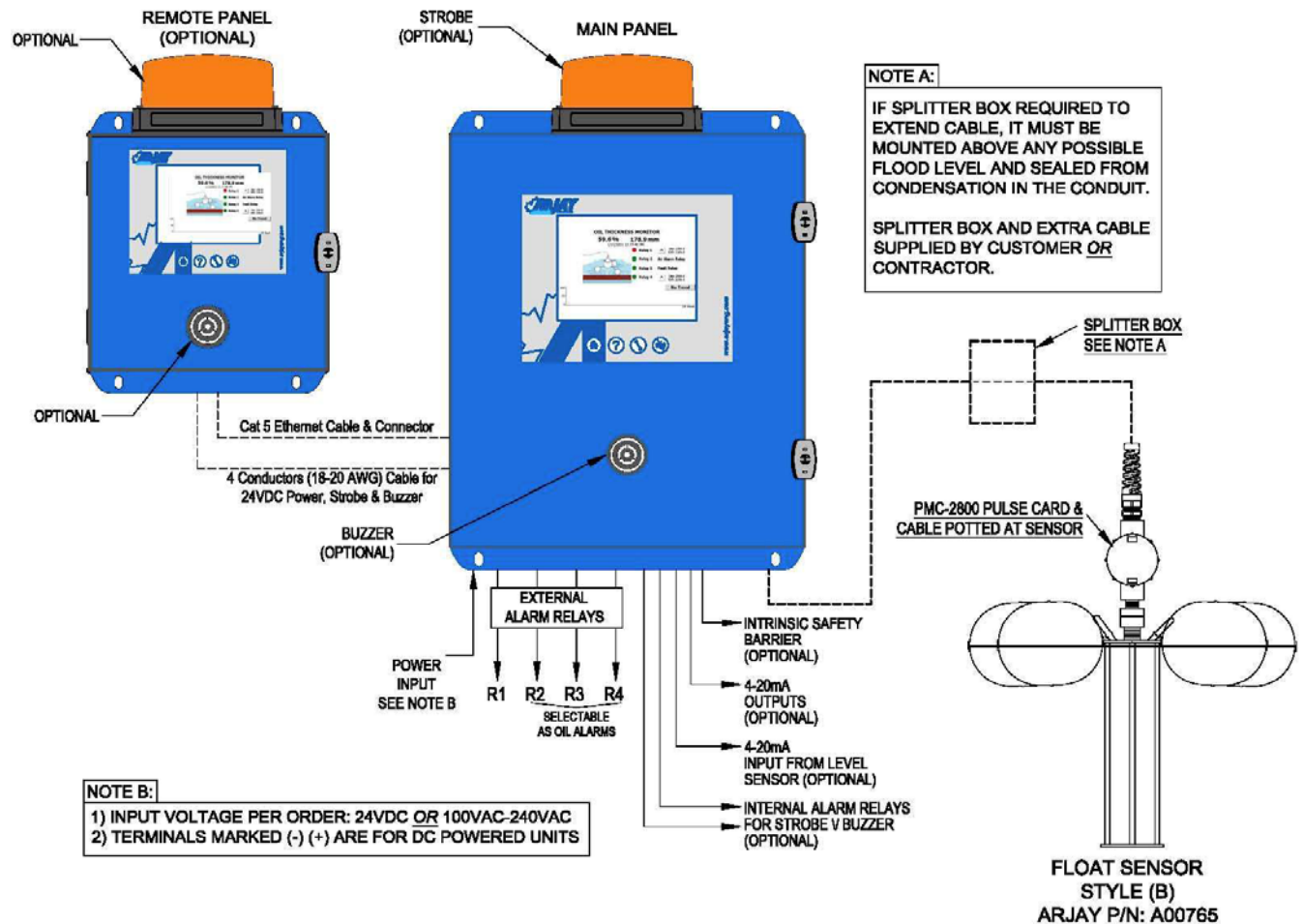

Figure 4 – Electrical Installation Overview

### Wiring

The main control panel supplies a 24 VDC power signal to the PMC card installed in the floating sensor. When the sensor float is connected, the voltage is 8 – 13 VDC across the + & - terminals of probe input of an App Board.

The PMC card drops a frequency pulse onto the sensor wiring for a return signal to the main control unit. Float sensor comes with 30m (100ft) cable. Any extra length would require a weatherproof splitter box and 3 conductor shielded hook up cable.

A typical wiring type is 20AWG 3 conductor shielded (Belden #8772 or equivalent).

\*Shielded wire is required on all installations.

Maximum wire length is 1km between controllers to sensor float.

Refer to the detailed electrical drawings included at the back of this manual.

## 5.1 Permanent Power Connection (AC Powered Models Only)

- 1) Connection to the building wiring system shall be in accordance with the Canadian Electrical Code (CEC), Part 1 in Canada, the National Electrical Code, ANSI/NFPA 70 in the USA, or the local electrical codes of the country where the equipment is being installed.
- 2) A disconnecting device is required. The disconnecting means shall disconnect all current-carrying conductors.
- 3) 15A circuit breaker or equivalent fuse is required.
- 4) An external switch or breaker shall be in close proximity to the equipment and within easy reach of the operator. The switch shall be marked as the disconnecting device for the equipment and include the symbols to its "ON" and "OFF" positions using the following symbols:



- 5) The wiring for AC power should be minimum 18 AWG / 300V or as required by local / country codes.
- 6) After field wiring, the primary wires must be secured to the enclosure by tie-wraps to maintain the separation from the signal wires.
- 7) Wiring diagram for permanent connection: See drawings at the back of this manual.
- 8) Use copper conductors only.

## 5.2 Glossary Of Symbols

	Attention, consult accompanying documents <i>Attention, veuillez consulter les documents ci-joints.</i>	
	Primary Protective Earth Ground <i>Primaire de terre de protection</i>	
	Secondary Earth Ground <i>Mise à la terre de secondaire</i>	
	Direct Current (DC) <i>Courant continu</i>	
	Normally closed relay contacts <i>Contacts Repos</i>	<b>L</b>
	Power on <i>Marche (mise sous tension)</i>	<b>G</b>
		<b>N</b>
		Fuse <i>Coupe-circuit; fusible</i>
		Normally open relay contacts <i>Contacts travail</i>
		Power off <i>Arrô (mise hors tension)</i>
		Live <i>Sous tension</i>
		Ground <i>Terre</i>
		Neutral <i>Neutre</i>



## 6.0 STARTUP

### 6.1 Startup

Check that the power wiring and connections to the main panel, remote panel, floating sensor and interfaced equipment are wired in accordance with the electrical installation drawings.

Power On the unit.

The main screen will light up and run through initialization. After any power interruption, the system will run through this same 30 second initialization.

The main and remote panels are set to factory defaults or customer specifications. **After the initial installation, the alarm and output functions must be set by the customer and a process calibration is required.** These entries are retained in the CPU memory and are not required after any further power disruption.

Confirm the screen reads similar to the following.

#### *Without Level Sensor Main Screen*

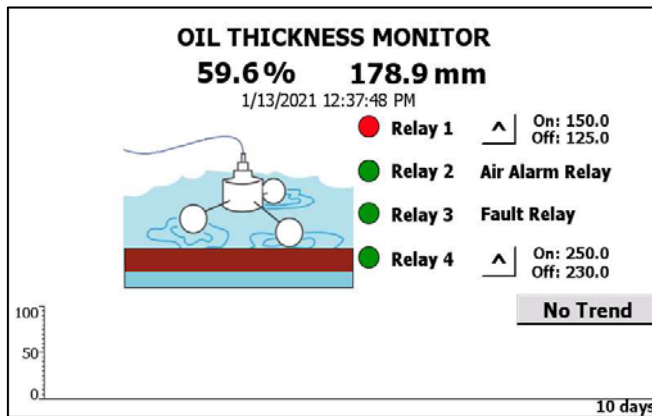

#### *With Level Sensor Main Screen*

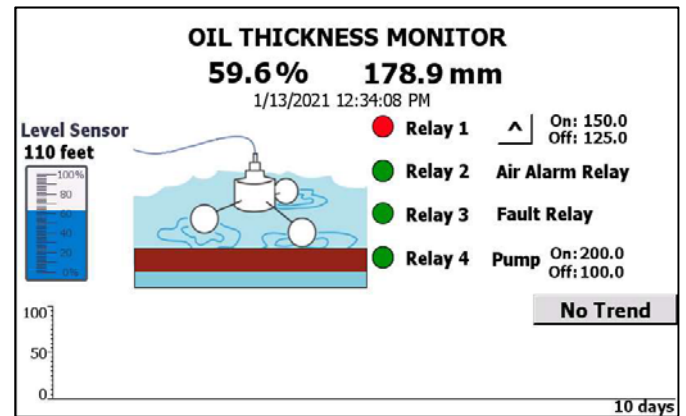

Figure 5 – Main Screen View

### 6.2 Screen Menu Background Information

**\*\*Screen saver is available thru Control Panel setup at initial Start-up.**

The Trend View logs and provides a graphic display of the oil level readings during the past 10 days. This view can be hidden. (Press “No Trend” icon).

In addition to the standard % display, the screen will display in any engineering units entered. Note that the engineering units must be directly proportional to the % level for the reading to be accurate. For example, a volume in liters will be proportional to an oil level in a vertical straight walled sump but will not be proportional to a level in an open pond. The full scale value of units, such as liters or mm at the determined 100% maximum oil level will be required to be entered during calibration.

Note: The 100% oil depth is a maximum of 25mm for the A00761 style sensor and 300mm for the A00765 style sensor.



## 6.2.1 Keypad Main Menu Entry

Below the touch screen are 4 touch keys (see below keypad image):



At any time, you can press the Home Key to return directly to the Home Screen



This provides serial number information and an overview of the system operation and components. Contact details for technical help are included at the end of the text.



Access this section to view or configure the screen and control settings, view diagnostics and perform a calibration



During an alarm condition the audio can be silenced. Silencing at any panel will silence all panels. The audio alarm will automatically re-set when the alarm clears.

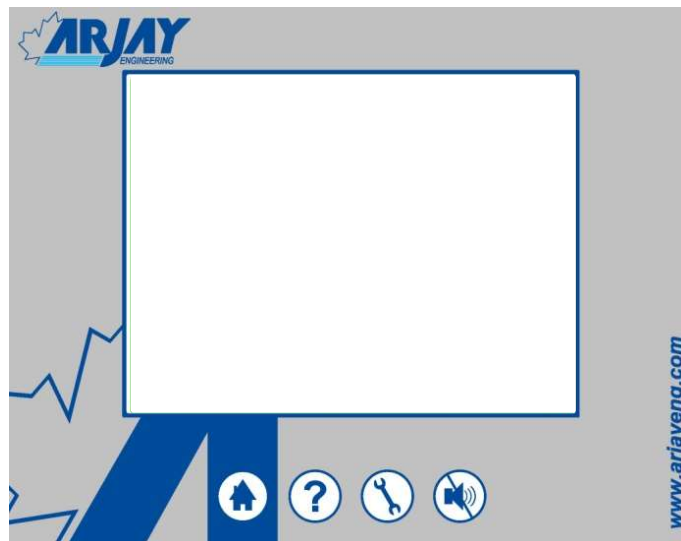

## 6.2.2 Password

This model has a touchscreen display. Tap the icon that you wish to change. A keyboard will display for your changes. Press the Return Key to complete.

Accessing any screen that allows parameters to be changed will require a password. The factory password is 2000. Touch within the Password box, a keyboard will display. After the password is entered, press the Return key  to complete. Then press OK in Login screen. Menu can then be accessed.

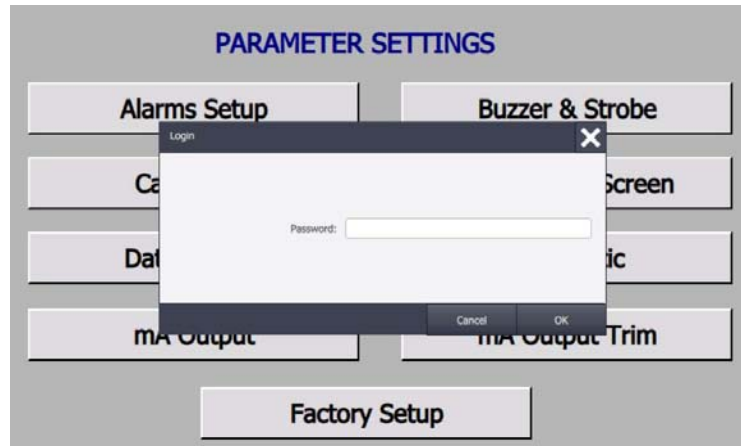

Figure 6 – Password Screen View

## 7.0 CONTROLLER NETWORK

This section describes the screen, alarm and interface features accessed through the Main Panel. See Controller Setting Sheet (Section 9.0) in back of manual for Factory Default values. mA Output and mA Output Trim is optional function.

Press “”

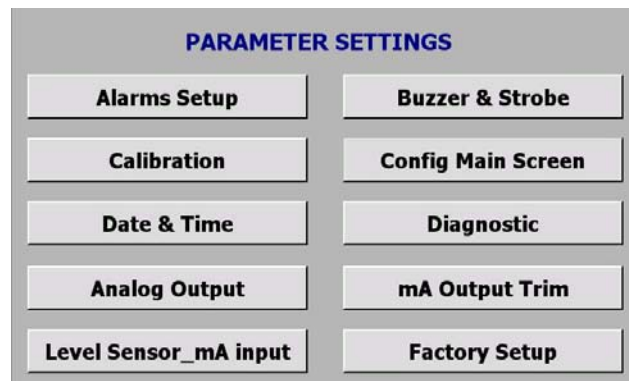

Figure 7 – Parameter Settings Screen View

Enter into the following menu items to configure your monitor

### 7.1 Configure Main Screen View

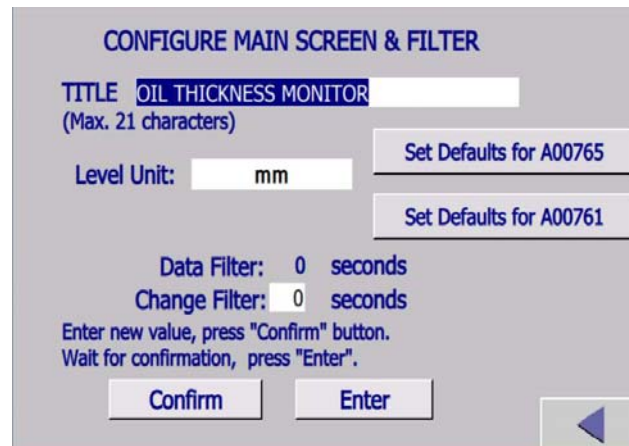

Figure 8 – Configure Main Screen View

The Password 2000 will be required to make changes in this section.

**Title:** You can personalize the main screen title to your application or tag # (ie, Sump #6 - LT-4505). Touch the TITLE block and type in your description. The factory default is OIL THICKNESS MONITOR.

**Level Unit:** This is the engineering unit that will displayed for the level of oil. This is factory defaulted to millimeters (mm). You can change this to any units of your choice by touching the Level Unit icon and entering your desired units. Note: Any change in units will require a conversion to the slope used in calibration.

**Data Filter:** Filtering is used to suppress rapid spikes by adding time delay to the response rate. For example, a sudden change of 40% could cause a valve to move too quickly and upset the process conditions. Adding 10 seconds of delay will dampen the display measurement and mA output so that it approaches the 40% change over a period of 10 seconds. If the level returns to a lower point, the mA will follow the new path with the same dampening affect.

## 7.2 Alarms Setup

The Password 2000 will be required to make changes in this section.

There are four relays available.

Relay 1 (R1) is set as General purpose use for Oil alarm setpoints (factory default), valve control, etc.

Relay 2 (R2) is set as an Air alarm (factory default). An air alarm may occur when the sensor is out of the water due to maintenance, no water in sump or obstruction of float sensor from floating properly in the water. To disable the factory default setting for relay 2 to act as Oil Alarm, press **“Enabled Relay 2 as Air Alarm relay”**.

Relay 3 (R3) is set as a Fault (factory default). A fault alarm may occur when there is no signal from sensor to main controller. To disable the factory default setting for relays 3 as Fault, press **“Enabled Relay 3 as fault relay”**.

Relay 4 (R4) is set as Oil Alarm (factory default). Relay 4 can be set as (1) Pump Run relay with a timed and auto shut-off feature or (2) Level sensor. The pump run relay that initiates a pump at a prescribed % level of oil and then runs for a determined amount of time. The relay will deactivate the pump after the run time or when the oil level returns to pump reset level on the sensor, whichever occurs first. The purpose of the run time feature is to allow a pump to run based on a desired volume evacuation of oil without running dry or pumping water out. To disable the factory default setting for relay 4 to act as Pump run or Level sensor, press config button then select which feature for relay 4.

Relay 4 set as a Pump Run relay option,.

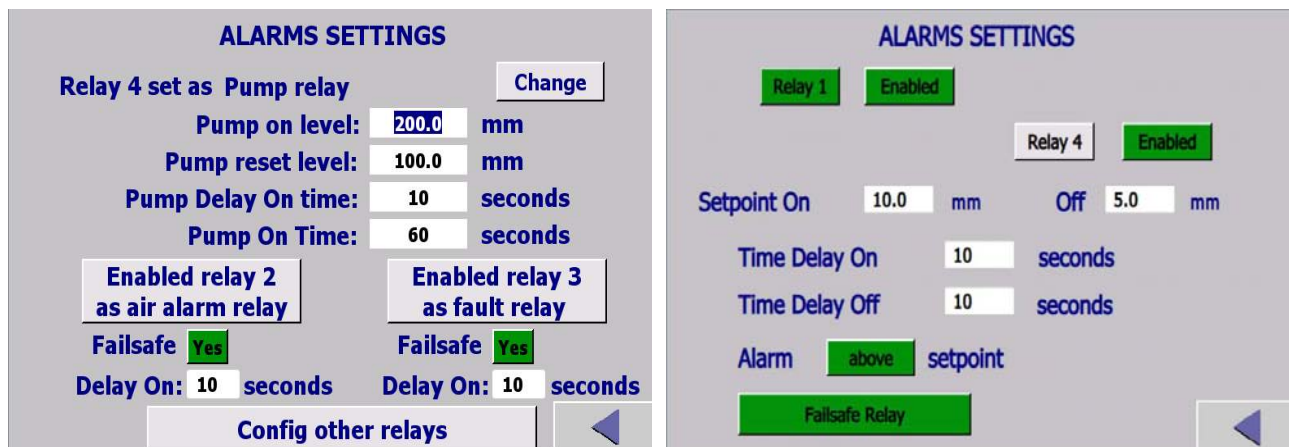
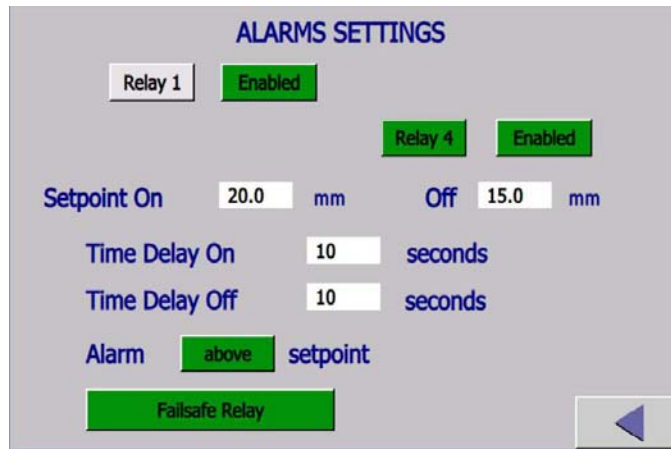

Figure 9 – Alarm Setting Screen View (Disabled Relay 3 & 4)

To set up Relays 1, 2\*\*, 3\*\* and/or 4\*\*, Enter “Config other relays” button. If the icon beside each Relay indicates Enabled, the relay is functional. Pressing the Enabled icon to display Disabled will render the relay Disabled and will remove that relay from the main screen display. It will disable the relay from functioning. If it presently reads Disabled, press the icon to Enable the relay.

\*\*If selected as oil alarm only or level sensor for relay 4.



**Figure 10 – Alarm Setup Screen View**

Touch Relay 1 icon so that it is green. Enter the values of parameters described below.

### **Setpoint ON**

This will determine the setpoint level in engineering units (% for R4 level sensor option) at which the alarm relay activates.

### **Setpoint Off**

This will determine the setpoint level in engineering units (% for R4 level sensor option) at which the alarm relay will turn off. This differential feature is used to suppress chattering of alarms if the level is hovering at the setpoint or can be used to control the differential on/off of a pump or valve.

### **Time Delay**

**Delay ON:** This is the time, in seconds, that the relay will delay before activating when the alarm setpoint has been reached. Delay ON is used to suppress a nuisance alarm that may be caused by a spurious or momentary alarm condition.

**Delay OFF:** The time, in seconds, that the relays will stay on after the level has returned to a normal condition. Delay OFF is used to keep controls activated after the alarm has cleared to ensure a stable normal condition has been reached.

### **Alarm Above or Below Setpoint**

This function is to guide the controller on how to control the failsafe and LED indications on the screen.

Select ABOVE if the requirement is for the relay to alarm when the % rises above the setpoint.

Select BELOW if the requirement is for the relay to alarm if the % drops below a setpoint.

The parameters are now set for relay 1. Repeat the above step for rest of the other Enabled relays.

### **Failsafe**

Failsafe will determine if the relays are energized or de-energized during a normal operating state (no alarm condition).

If Failsafe is YES, the relay will be energized during a normal operating condition. An alarm or power failure will de-energize the relay to the alarm state.

When in Failsafe mode and during a normal condition, the N.O. contact is closed and the N.C. contact is open. WIRE ACCORDINGLY.

## Relay 4 (Pump Run Selection)

Relay 4 can also be selected as Pump Run relay. Follow the following steps to setup the Pump Relay 4

Pump On Level: Enter level of oil at which the pump is to turn on.

Pump Reset Level: Enter level of oil at which the pump is to turn off and reset timing feature.

Pump Delay On Time: Enter the time in seconds that the pump should be delayed before coming on after the alarm setpoint has been reached. Adding time delay will suppress the relay from activating due to a spurious alarm condition caused by an intermittent surge, etc.

Pump On Time: This is the time that the pump will run after it has been activated. The time should be limited so that the oil does not drop below the suction intake tube of the pump, which would cause the pump to run dry. The flow rate of the pump and volume vs. level of the sump will be needed to determine this accurately.

<b>NOTICE</b>	<b>Pump will Turn Off when oil level returns to pump reset level OR pump On time, whichever comes first.</b>
---------------	--

## 7.3 Date and Time

The 4100-HCF has a real time clock to show current date and time. Press change button to modify the current date and time if required. Press Enter to update the modified date and time.

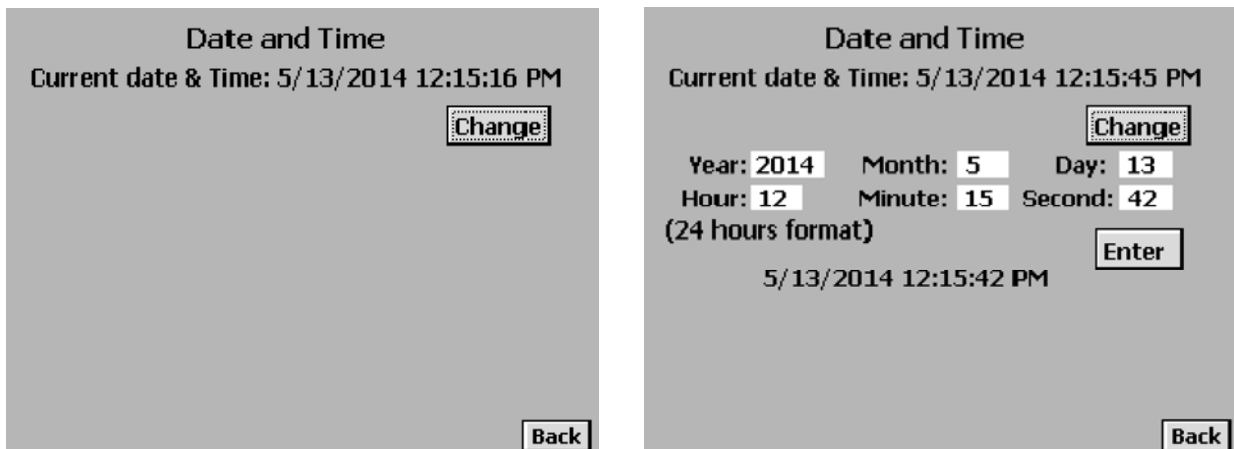

Figure 11 – Date and Time Screen View

## 7.4 Analog (mA) Output (Optional)

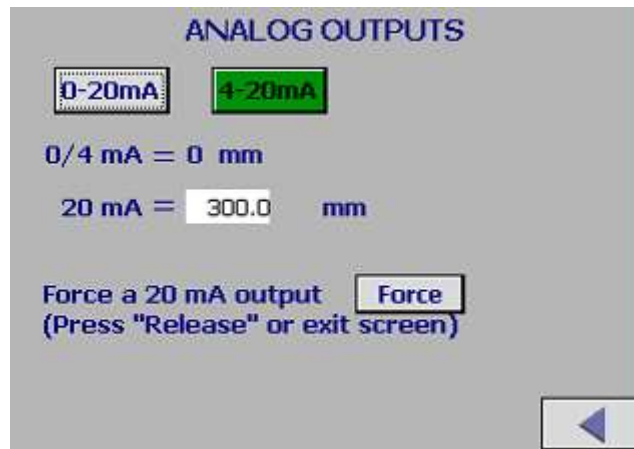

Figure 12 – Analog Output Screen View

The Passcode 2000 will be required to make changes in this section

### 0-20mA vs 4-20mA

Select the mA output range for your application. The green icon will confirm which range is selected.

### 0/4 mA = 0 and 20 mA = xx (Engineering Unit)

The 0 or 4 mA is factory defaulted to 0 oil level. The 20 mA may be offset to suit your control requirements and is entered in engineering units. Typically 20 mA is set to the engineering unit value for 100% depth of Oil i.e. 25 mm or 300 mm depending on sensor style. For maintenance purposes to check external equipment and alarms or the analog output, the 20mA output can be forced by pressing the “Force” icon beside “Force a 20mA output”.

## 7.5 mA Output Trim (Optional)

**mA Output Trim:** Allows user to trim/modify mA output values. This modification requires a special password which can be obtained from Factory (Arjay Engineering Ltd.) if required.

## 7.6 Buzzer and Strobe Beacon (Optional)

Allows a Buzzer or Strobe Beacon is ordered, they are factory wired to internal relays. They can be set in the same way as the Alarm relays. See section 7.2.

The buzzer can be silenced by the keystroke button “” on the main screen”. It will automatically reset.

The strobe can be selected to latch. If latch is chosen, an icon will display after an alarm to clear.

## 7.7 Level Sensor mA Input (Optional)

The following menu is used to display level of the sump or tank from an external mA level transmitter. This feature can be enabled or disabled using passcode 2000 (Factory default is disabled). At 4 mA input enter the value and unit of measurement that is to be displayed. At 20 mA enter full scale value and unit of measurement. The following level measurement will display on the left hand side of the HMI display. mA trim is used for factory use only.

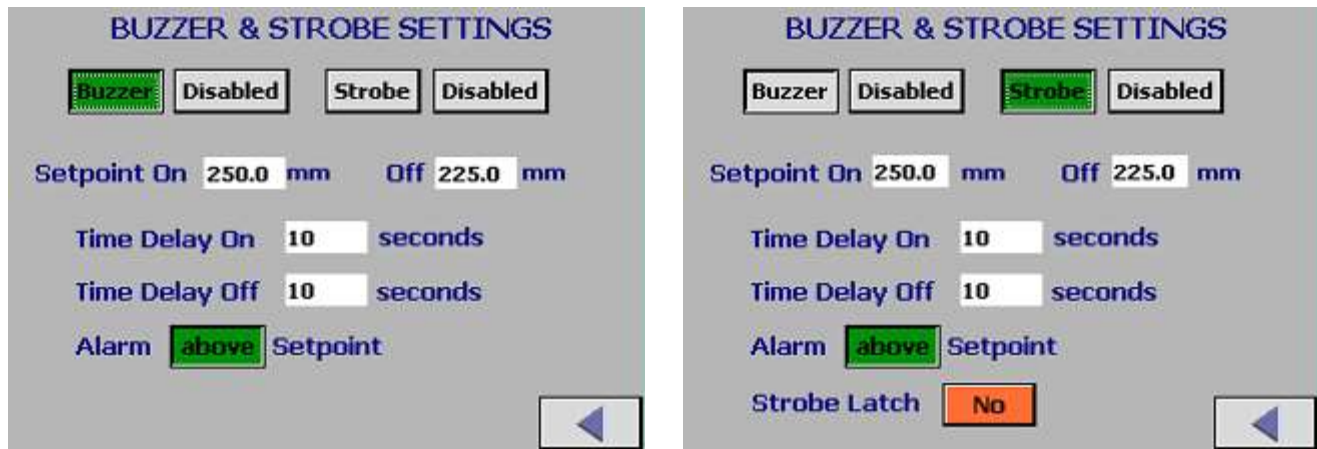

Figure 13 – Buzzer & Strobe Setting Screen View

## 7.8 Calibration

After the above setup parameters have been entered for the application, a Pulse Card set up is required. Confirm the current A, K and C values shown on the screen match with the values provided inside the Junction box of the floating sensor (A00765) or on the side of float (A00761). Also provided in section 9.0 of manual. If the values are different, Press the “Change” button on the screen. Enter the A, K and C values and press “Enter” and the screen will show “Entered”.

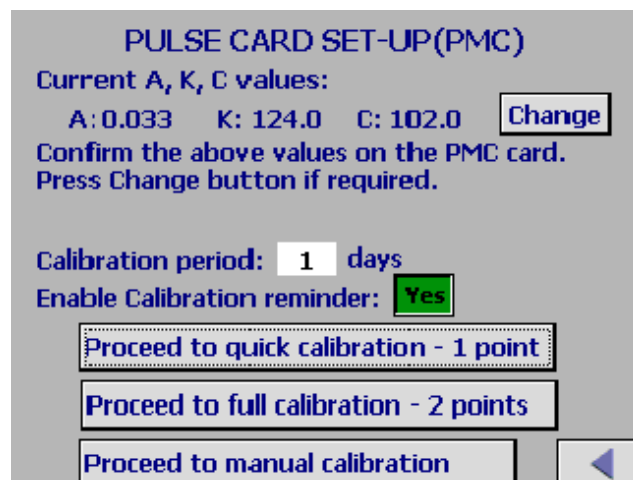

Figure 14 – Pulse Card Set-up Screen View

Once the PMC set-up is completed, a process calibration is required. The float sensor must be floating on oil or water in order to perform the calibration. Preference is to calibrate in clean water.

### Calibration Reminder

The 4100-HCF has a real time clock. After calibration, the calibration date is recorded in the diagnostics. A calibration reminder can be set for up to 999 days. This is enabled by pressing the “CAL REMINDER” icon. This icon will appear again on the main screen after the preset number of days is reached. If a calibration can be done, Press the “Recalibration” icon.

If a calibration cannot be performed at the time of the reminder, this can be reset to a later date by entering the number of days until the next reminder is desired. Press “Enter” icon to activate the Reminder countdown.



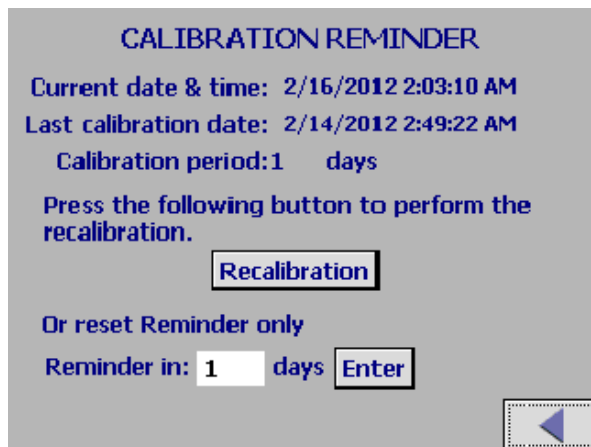
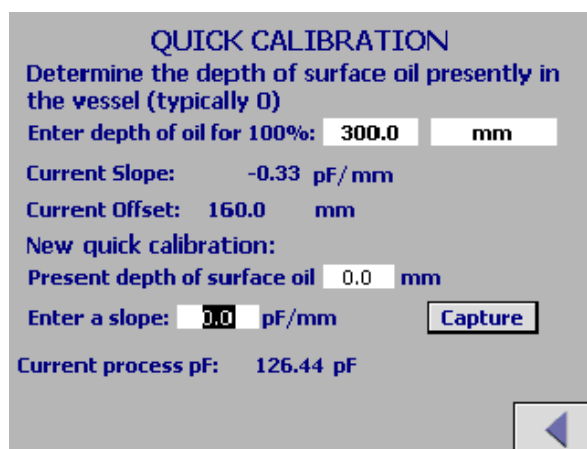

**Figure 15 – Calibration Reminder Screen View**

This unit allows for three types of calibration.

### 7.8.1 Quick Calibration

This would be the most typical calibration and uses a factory defaulted slope to allow for a single entry calibration point.



**Figure 16 – Quick Calibration Set-up Screen View**

#### Display Units

Choose the engineering units you want on the display, such as inches, mm, cm, liters, etc. (Factory default is mm)

After entering each value for the following parameters, Press, “Enter” to confirm. Screen will change to “Entered” if accepted.

#### Depth of oil for 100%

For the chosen engineering units, enter the total oil thickness that will represent 100% oil. This will typically be 25mm for sensor A00761 and 300mm for sensor A00765.

#### Present Depth of surface oil

Enter the present thickness of surface oil on the water. Enter this in your chosen display units. If no oil is present, enter 0.0.

#### Slope

This is factory preset. The factory default is in pF/mm. If the display engineering units have been changed (ie. to inches), the slope must be mathematically corrected and re-entered.

\*\*A00761 = 0.50 pF/mm would be 12.7 pF/inch  
 \*\*A00765 = 0.182 pF/mm would be 4.623 pF/inch  
 \*\*The above values are based on oil at a dielectric constant of 2.2.

### Capture

Once the above information has been entered, Press “Capture”. The screen should indicate “Captured”. If all values have been entered and captured then a “Press to Calibrate” button will appear at the bottom of the screen. Press Button. A successful calibration will show a “Calibration OK” icon.

Press the Home Key  to return to the main screen.

**The Arjay 4100-HCF is now set up, calibrated and operating to your process conditions.**

### 7.8.2 Full Calibration

This will enhance the factory defaulted slope value to your specific oil type but will require an accumulated level change of oil. Proceed with same calibration procedure as Quick Calibration (Section 7.7.1); for the 2<sup>nd</sup> point, an oil level change is required.

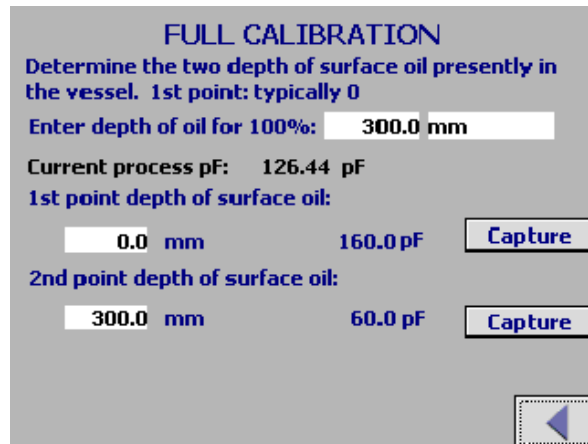

Figure 17 – Full Calibration Set-up Screen View

### 7.8.3 Manual Calibration

This allows a user to override any of the previous calibration values and enter predetermined or observed calibration values. For the Quick calibration the second cal point was determined from slope and depth of oil for 100%.

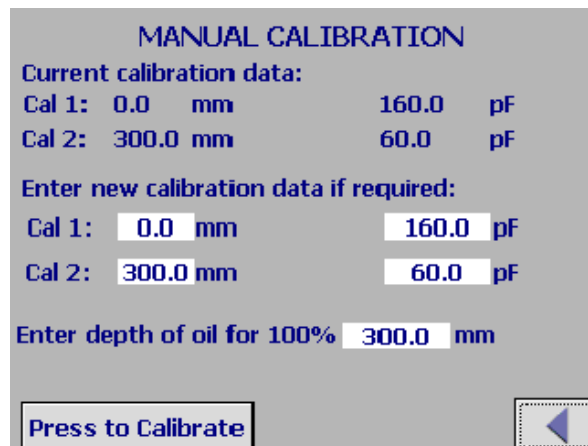
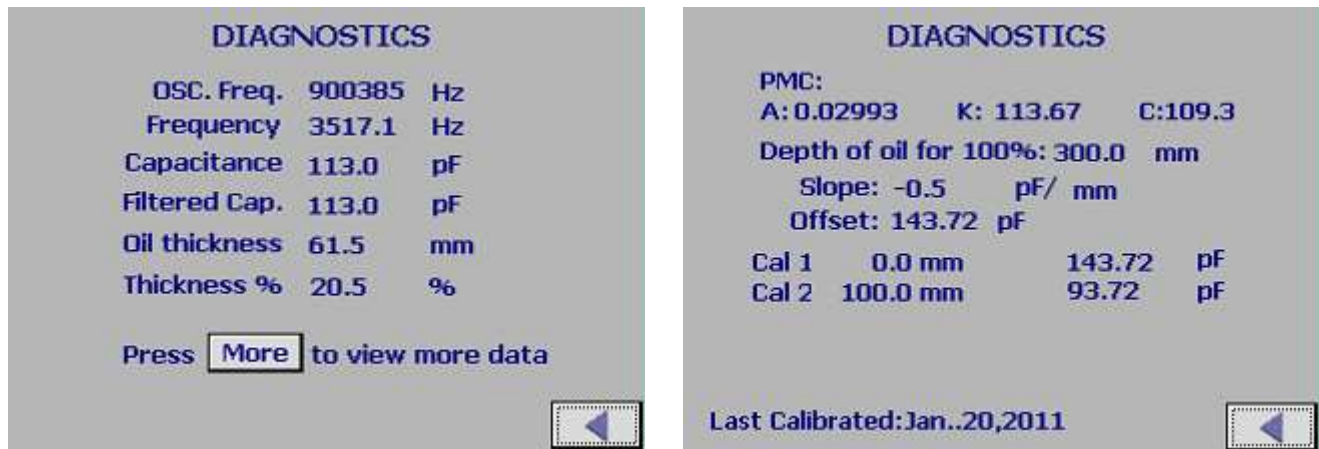

Figure 18 – Manual Calibration Set-up Screen View

## 7.9 Diagnostic Information



**Figure 19 – Diagnostic Information Screen View**

These are only View Only screens. They provide various diagnostic information that is communicating between the sensor and the controller or has been entered during a calibration. This is a real-time display and is a valuable tool to observe process data such as product stability and change. If technical assistance is required during the setup or operation of the instrument, record or photograph these screens prior to contacting Arjay.

**Oscillation Frequency:** This is the frequency at which the probe is tuning itself as the product level changes. The frequency change is inverse to level. 0 Hz indicates there is no frequency to the pulse card and the sensor may be disconnected.

**Frequency:** For stability and transmission to the main controller, the oscillation frequency of the probe is divided and linearized to a lower frequency in the PMC card. This response is also inverse to level.

**Capacitance:** This is the sensor, oil/water and tank capacitance reading in picofarads. At 0% oil level there will be an offset capacitance due to the sensor.

**Filtered Capacitance:** During the screen set-up, there will be an opportunity to filter the output to dampen spikes. If filtering has been entered, this reading will respond slower than the true process capacitance.

**Oil Thickness:** If a calibration has been done, the engineering unit values are available here.

**Thickness %:** If a calibration has been done, the % oil thickness of span is available here.

Press “More” to view more data:

**PMC:** There is a Pulse Card (PMC) potted within the sensor. During calibration, the operator is required to enter the A,K, C values that are labeled in the junction box of floating sensor (A00765) or side of the sensor float (A00761) as well as in the back of the manual under controller settings (Section 9.0). These 3 values are unique to each PMC card and enhance the response, accuracy and linearity of the tank capacitance for optimum performance.

**Depth of Oil for 100%:** During calibration, the operator will be required to enter a value that represents 100% oil. This is the value that was entered with selected engineering units.

**Slope:** A slope of pF vs oil level has been factory set for this model to aid in automatic calibration. This is set as pF/mm. It is important to convert this value when changing engineering units. e.g. Inches would be converted from 0.182 pF/mm to 4.623 pF/inches (A00765 Float). This slope is based on diesel fuel at 2.1 dielectric constant.

**Offset:** The offset is the capacitance of the sensor in the vessel under a 0% oil condition.

**Calibration Points:** These are the calibration values recorded after the last successful calibration.

**Last Calibrated:** During a successful calibration, the calibration date will be recorded.

# 8.0 TROUBLESHOOTING

## Main Panel

Press “” for some troubleshooting tips.

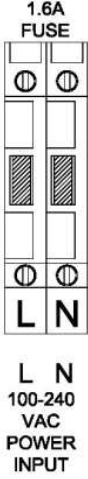
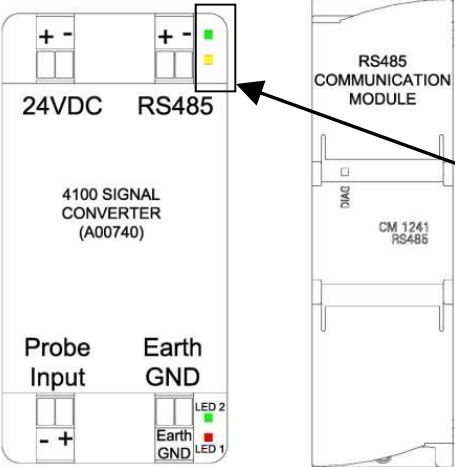
	<p><b>Condition: Power Supply Status</b></p> <ul style="list-style-type: none"> <li>• Confirm the Power Supply LED is active (Green).</li> </ul>
	<p><b>Condition: Power Input Status</b></p> <ul style="list-style-type: none"> <li>• Confirm the Power input is 100-240 VAC using a meter.</li> <li>• Confirm if input fuse has blown.</li> </ul>
	<p><b>Condition: Communication Error</b></p> <ul style="list-style-type: none"> <li>• Means no communication between 4100 Signal Converter (A00740) and RS485 (CM1241) Module.</li> <li>• Under normal operating conditions, both LED's should be Lit and Flashing continuously.</li> <li>• Check wiring between 4100 Signal Converter (A00740) and RS485 (CM1241) Module.</li> <li>• Confirm 24VDC power to 4100 Signal Converter (A00740).</li> </ul>

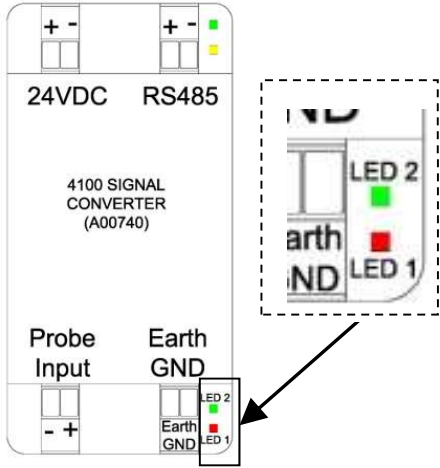
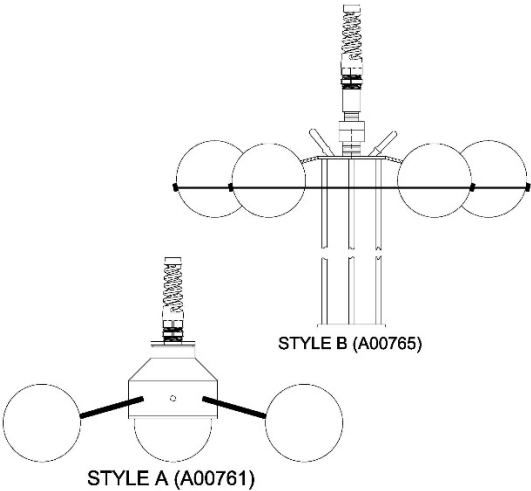
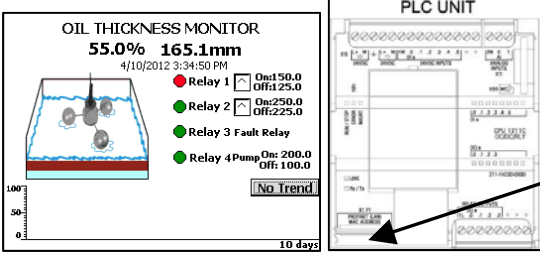
 <p>24VDC RS485</p> <p>4100 SIGNAL CONVERTER (A00740)</p> <p>Probe Input Earth GND</p> <p>LED 2 LED 1</p>	<p><b>Condition: No Transmitter Signal (Status LED is Red)</b></p> <ul style="list-style-type: none"> <li>• Under normal operating conditions, LED 2 should be Green. If there is an error, LED 1 goes Red.</li> <li>• Make sure the float sensor wiring is correct and there are no breaks in the wiring. At the 4100 signal converter (A00740), measure across the + and - terminals with a DC meter. Make sure “Common” lead of meter is on ‘-’ terminal. It should read (+) 8 to (+) 13 VDC with the sensor connected and approximately 20-24 VDC with the sensor disconnected from the terminal.</li> <li>• Replace sensor float if suspect water damage OR possible power outage may have damaged the pulse card within.</li> </ul>
 <p>STYLE B (A00765)</p> <p>STYLE A (A00761)</p>	<p><b>Condition: False Alarm</b></p> <ul style="list-style-type: none"> <li>• Check that any excess cable is interfering with the float travel. Cut back any excess.</li> <li>• Make sure there is no external interference and electrical noise such as agitators, high voltage interference, turbulent flow, etc.</li> <li>• Make sure the sensor is floating on water and is unobstructed. The complete Teflon coated probe should be submerged.</li> <li>• Confirm proper slope with correct engineering units were entered at calibration.</li> </ul>
 <p>OIL THICKNESS MONITOR</p> <p>55.0% 165.1mm</p> <p>4/10/2012 3:34:50 PM</p> <p>Relay 1 On:150.0 Off:125.0</p> <p>Relay 2 On:250.0 Off:225.0</p> <p>Relay 3 Fault Relay</p> <p>Relay 4 Pump On: 200.0 Off: 100.0</p> <p>No Trend</p> <p>10 days</p> <p>PLC UNIT</p>	<p><b>Condition: Communication Error</b></p> <ul style="list-style-type: none"> <li>• If LCD display shows “##”, check the condition of Ethernet wire connected between HMI display and PLC unit for no breaks.</li> <li>• Make sure the Ethernet wire is not loose from PLC or HMI terminal.</li> </ul>
	<p><b>Condition: Out of Range</b></p> <ul style="list-style-type: none"> <li>• Check that the correct AKC values are entered in calibration menu. These values are on the side of floating sensor (A00761) or inside junction box (A00765) OR Section 9.0 of the manual.</li> </ul>

## 9.0 CONTROLLER SETTING SHEET

Checked by	
Model Number	
Serial Number	
Software Rev.	

PARAMETER	DESCRIPTION	FACTORY SETTING	USER SETTING
PMC A value	PMC-2800 setup parameters		
PMC K value	PMC-2800 setup parameters		
PMC C value	PMC-2800 setup parameters		
Engineering Unit	Chosen engineering units for depth of oil	<b>mm</b>	
Slope	Factory installed value of capacitance per level change of oil or diesel fuel	<b>0.50pF / mm (A00761) <i>or</i> 0.182 pF/mm (A00765)</b>	
Offset	Result of a successful Calibration: Calculated capacitance for 0% oil.		
Depth of Oil for 100%	The total oil thickness that will represent 100% Oil.	<b>25 mm (A00761) <i>or</i> 300mm (A00765)</b>	
Zero	Zero Level value for mA output (in chosen engineering units).	<b>0 mm</b>	
Span	Full Scale Oil thickness value for mA output (in chosen engineering units).	<b>25 mm (A00761) <i>or</i> 300 mm (A00765)</b>	
mA Range	0-20mA OR 4-20mA	<b>4-20mA</b>	
Relay 1: <i>Hi Set</i>	Alarm Relay 1 high alarm: alarm condition if level is above this value (value in chosen engineering units).	<b>10 mm (A00761) <i>or</i> 150 mm (A00765)</b>	
Relay 1:OFF	Alarm relay 1 differential off value	<b>5 mm (A00761) <i>or</i> 125 mm (A00765)</b>	
Relay 1: <i>Failsafe</i>	Failsafe ON sets the relay as normally energized (no alarm) and de-energized in an alarm condition.	<b>ON</b>	
Relay 1: <i>Alarm Action</i>	Alarm action above OR below alarm level	<b>Above</b>	
Relay 1: <i>Alarm Delay (ON)</i>	Amount of time the level must be in an alarm condition (based on Relay 1 alarm value and	<b>10 sec</b>	

	Action settings) before the relay trips to the alarm condition (condition set by Relay 1 Failsafe setting).		
Relay 1: <i>Alarm Delay (OFF)</i>	Amount of time the level must stay in an alarm condition (based on Relay 1 alarm value and Action settings) before the relay trips to the normal condition (condition set by Relay 1 Failsafe setting).	<b>10 sec</b>	
Relay 2: <i>Air Alarm</i>	Alarm Relay 2 air alarm: alarm condition if water level is below float sensor or dry condition. Can also be selected as an oil alarm relay	<b>Air Alarm</b>	
Relay 2: <i>Failsafe</i>	Failsafe ON sets the relay as normally energized (no alarm) and de-energized in an alarm condition.	<b>ON</b>	
Relay 2: <i>Alarm Delay (ON)</i>	Amount of time the level must be in an alarm condition (based on Relay 2 alarm value and Action settings) before the relay trips to the alarm condition (condition set by Relay 2 Failsafe setting).	<b>10 sec</b>	
Relay 3: <i>Fault</i>	This relay indicates Instrument Failure. It can also be selected as an Alarm Relay.	<b>Fault</b>	
Relay 3: <i>Failsafe</i>	This relay is factory default to be normally energized (no alarm) and de-energized in an alarm condition or power failure.	<b>ON</b>	
Relay 3: <i>Alarm Delay (on)</i>	Amount of time the level must be in an alarm condition (based on Relay 3 alarm value and Action settings) before the relay trips to the alarm condition (condition set by Relay 3 Failsafe setting).	<b>10 sec</b>	
Relay 4: <i>Hi Set</i>	Oil Alarm Relay 4 high alarm: alarm condition if level is above this value (value in chosen engineering units). Level sensor input: Value chosen as %	<b>20 mm (A00761) or 250 mm (A00765)</b>	
Relay 4: <i>OFF</i>	Oil Alarm Relay 4 differential off value Level sensor input: Value chosen as %	<b>15 mm (A00761) or 225 mm (A00765)</b>	
Relay 4: <i>Failsafe</i>	Failsafe ON sets the relay as normally energized (no alarm) and de-energized in an alarm condition.	<b>ON</b>	
Relay 4: <i>Alarm Action</i>	Alarm action above OR below alarm level	<b>Above</b>	
Relay 4: <i>Alarm Delay (ON)</i>	Amount of time the level must be in an alarm condition (based on Relay 4 alarm value and Action settings) before the relay trips to the alarm condition (condition set by Relay 4 Failsafe setting).	<b>10 sec</b>	
Relay 4: <i>Alarm Delay (OFF)</i>	Amount of time the level must stay in an alarm condition (based on Relay 4 alarm value and Action settings) before the relay trips to the normal condition (condition set by Relay 4 Failsafe setting).	<b>10 sec</b>	



Relay 4: Pump Hi Set <b>If Pump option Selected</b>	Pump (Relay 4) high alarm: pump (relay 4) turned on for a selectable time when oil level exceeds this value. The pump will not turn on again until the level drops below the reset level or pump timer is complete. Note: alarm value in chosen engineering units.	<b>Not used</b>	
Relay 4: Pump Reset Level <b>If Pump option Selected</b>	Oil level that pump will reset.	<b>Not used</b>	
Relay 4: Pump ON Delay <b>If Pump option Selected</b>	Amount of time the oil level must be above the Pump High Setpoint before the pump relay is energized	<b>Not used</b>	
Relay 4: Pump ON time <b>If Pump option Selected</b>	The time in seconds for which the pump is turned on when the oil level first exceeds the PUMP HI SET value (Relay 4 Hi Set).	<b>Not used</b>	
Relay 4: Pump Failsafe <b>If Pump option Selected</b>	This relay is forced to be normally de-energized (Failsafe = OFF) since it controls a pump which should be OFF if power to the 4100 HCF is removed.	<b>Not used</b>	<b>No change allowed</b>
Filter	Digital Filter response time in seconds. Used to smooth out level fluctuations caused by splashing etc.	<b>0 sec</b>	
Tag Number (Optional)	For network applications only. All Arjay 4100 series controllers connected to a network must have a unique Tag Number between 1 and 100	<b>1</b>	
Optional Buzzer / Strobe Setting	Alarm Relay 2 high alarm: alarm condition if level is above this value (value in chosen engineering units).	<b>20 mm (A00761) or 250 mm (A00765)</b>	
Optional Buzzer / Strobe Setting	Alarm relay 2 differential off value	<b>15 mm (A00761) or 225 mm (A00765)</b>	
Optional Buzzer / Strobe Setting	Failsafe ON sets the relay as normally energized (no alarm) and de-energized in an alarm condition.	<b>ON</b>	
Optional Buzzer / Strobe Setting	Alarm action above OR below alarm level	<b>Above</b>	
Optional Buzzer / Strobe Setting	Amount of time the level <b>must be in</b> an alarm condition (based on Relay 2 alarm value and Action settings) before the relay trips to the alarm condition (condition set by Relay 2 Failsafe setting).	<b>10 sec</b>	
Optional Buzzer / Strobe Setting	Amount of time the level <b>must stay in</b> an alarm condition (based on Relay 2 alarm value and Action settings) before the relay trips to the normal condition (condition set by Relay 2 Failsafe setting).	<b>10 sec</b>	

## 10.0 MODBUS MAP AND DETAIL (OPTIONAL)

2 Wire RS-485 (1/2 Duplex)

**9600 Baud, Even parity, 8 Data bits, 1 stop bit.**

For connection to a PC, an RS-485 to USB converter module and modbus software (Modbus Poll, DAQfactory, etc.) be used.

The following RS-485-USB converter has been tested with the system:

**Model: UT-850** (Manufacturer: Gridconnect)

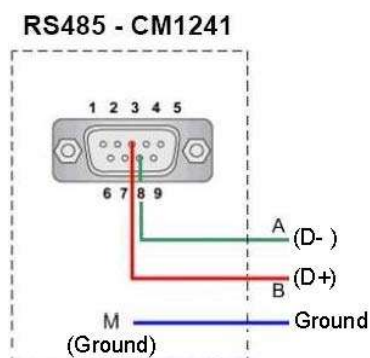

### 10.1 Modbus Commands Supports

After Read Coil Status Function Code: 01. Used to read relays output from PLC

Read Holding Registers Function Code: 03. Used to read values from PLC

### 10.2 Register Map

#### Read coils status (01)

coil	DESCRIPTION	TYPE
00001	relay 1 - low oil alarm (Q0.0)	bit
00002	relay 2 – Air alarm or Oil alarm (Q0.1)	bit
00003	relay3 - Fault or Oil alarm (Q0.2)	bit
00004	relay 4 – <i>Oil alarm or Pump run, or Level sensor_mA input level alarm (Q0.3)</i>	bit
00005	relay 5 - Strobe alarm (Q0.4)	bit
00006	relay 6 - Buzzer output (Q0.5)	bit

#### Read Holding Registers (03)

REG	DESCRIPTION	TYPE	No. of Reg
40001	Depth of oil for 100%	real	2
40003	Calibration Slope	real	2
40005	Calibration Offset	real	2
40007	A value	real	2
40009	K value	real	2
40011	C value	real	2
40013	Calibration point CAL 1 (Unit)	real	2
40015	Calibration point CAL 2 (Unit)	real	2
40017	Calibration point CAL 1 (pF) capacitance	real	2
40019	Calibration point CAL 2 (pF) capacitance	real	2
40021	Depth of Oil	real	2
40023	Percent of Oil	real	2
40025	Level sensor_mA input level depth	real	2
40027	Level sensor_mA input level percent	real	2

## 11.0 DETAIL ELECTRICAL AND DIMENSIONAL DRAWINGS

---

Drawings are included in this section that are specific to your model ordered.  
If drawings are not included here, record the serial number on the left outside wall of the main panel and contact:

**ARJAY ENGINEERING TECHNICAL SUPPORT**

**(800) 387-9487**

**+1 (905) 829-2418**

**[www.arjayeng.com](http://www.arjayeng.com)**