



MODELS:

2882-FCS / 2882W-FCS

**PROBE MOUNTED
FOAM CONTROL SWITCH**



USER MANUAL (REV: 1.0)

ARJAY ENGINEERING LTD.		
2851 Brighton Road Oakville (Toronto), Canada L6H 6C9	TEL: ++1 (905) 829-2418 FAX: ++1 (905) 829-4701 NORTH AMERICA: 1-800-387-9487	WEBSITE: www.arjayeng.com EMAIL: arjay@arjayeng.com

THIS PAGE INTENTIONALLY LEFT BLANK

TABLE OF CONTENT

NOTICE

Please read the Installation Notes (4.0) prior to locating and mounting the instrument.

1.0	SPECIFICATION	4
2.0	USE HAZARD INFORMATION.....	7
3.0	INSTRUMENT OVERVIEW.....	8
3.1	Features	9
3.2	Model Number Table	9
4.0	INSTALLATION.....	10
4.1	Probe Mounted Controller Installation	10
4.2	Probe Installation.....	11
5.0	CONTROLLER OVERVIEW.....	12
5.1	Input / Output Terminal Specification	13
5.2	Permanent Power Connection (AC Powered Models Only)	14
5.3	Glossary Of Symbols.....	14
6.0	STARTUP AND CALIBRATION.....	15
6.1	Startup	15
6.2	Menu Flow Chart Background Information	15
6.2.1	Menu Short Form.....	15
6.2.2	Menu Description.....	16
6.2.3	Data Entry.....	16
6.3	288X Controller Setup	16
6.3.1	Setup And Network.....	16
6.3.2	Relay Setup Menu	17
6.4	288X Controller Calibration	19
6.4.1	Site Calibration	19
7.0	CONTROLLER NETWORK.....	20
7.1	MODBUS Configuration	20
7.2	2800 Series MODBUS Register Mapping	21
8.0	MAINTENANCE.....	22
9.0	TROUBLESHOOTING.....	23
10.0	FLOW CHARTS.....	24

TABLE OF FIGURES

FIGURE 1 – TYPICAL 2882-FCS FOAM CONTROL APPLICATION.....	8
FIGURE 2 – PROBE INSTALLATION.....	11
FIGURE 3 – CONTROLLER OVERVIEW.....	12
FIGURE 4 – NO DIFFERENTIAL APPLICATION – HIGH LEVEL.....	18
FIGURE 5 – NO DIFFERENTIAL APPLICATION – LOW LEVEL	18

1.0 SPECIFICATION

Specifications are subject to change without notice

Specification	Details
Power Input: <i>(Specify voltage at time of Order)</i>	12VDC +15% /-10% or 24VDC +15% /-10%, 250mA maximum 100VAC – 240VAC +/- 10%, 50/60 Hz, 150mA maximum Note: DC input models must be supplied by Limited Energy power source. Limited Energy means compliance with one of the following requirements: <ul style="list-style-type: none"> - Class 2 circuit according to Canadian Electrical Code, Part, I, C22.1; - Class 2 circuit according to National Electrical Code, NFPA-70; - Limited Power Supply (LPS) according to IEC 60950-1; - Limited-energy circuit according to IEC 61010-1.
Connections to mains supply	Permanent (for AC/DC model)
User Interface: Display & Keypad Communication Interface:	Two line LCD display, Alarm status LEDs and Keypad for select menu or enter values Modbus (RS485)
Relays / Analog Outputs: Relay Outputs mA Signal Output	2 SPDT relays, Dry Contacts are 3A @ 250 VAC (Resistive), selectable failsafe or non-failsafe, selectable high or low acting alarm, programmable time delay: 0 – 600 seconds 4mA during Normal and 20 mA during an alarm condition, 900 Ohms max (24VDC Power) OR 450 Ohms max (12VDC Power). *Set for Relay 1 only
Instrument Performance: Measuring Range Accuracy Resolution Calibration	0 - 5000 pF (most applications are 100pF to 1000pF) 0.2% 0.05% of setpoint via network display 0.002% of Full Scale capacitance via network display Single point per relay: Auto calibration
Environmental: Operating conditions Ambient Temperature Process Temperature Maximum Process Pressure Relative humidity Altitude	Continuous -20 °C to +55 °C controller -60 °C to +200 °C Standard or Heavy Duty Probe -60 °C to +100 °C Flexible Tefzel Probe 1500 PSI / 10342 kPa 0 to 95% (non-condensing) ≤2000 m

Specification	Details
Installation Category	II
Pollution Degree	2
Equipment mobility	Fixed
Mechanical Specification:	Refer to Dimensional Drawing
Enclosure Protection Degree	IP65, Die-Cast Aluminum Junction, Painted (Blue) NEMA 4X, Die-Cast Aluminum Junction, Painted (Grey)
2880 Series Controller With Level Probe Certification	
Ordinary Locations:	<ul style="list-style-type: none"> • UL file number: E343390 • UL / IEC 61010-1, 2nd Edition, 2008/10/28 (Electrical Equipment for Measurement, Control, and Laboratory Use; Part 1: General Requirements) • CAN/CSA-22.2 No. 61010-1, 2nd Edition, 2008/10/01, (Electrical Equipment for Measurement, Control, and Laboratory Use; Part 1: General Requirements) • CE: UL / IEC 61010-1; IEC / EN 61000-4; ISO 9001:2008
Hazardous Locations:	<ul style="list-style-type: none"> •
<i>North America</i>	<ul style="list-style-type: none"> • CSA file number: 56812 • Class – 2258-02 – Process control equipment for Hazardous Locations • Class – 2258-82 – Process control equipment for Hazardous Locations – Certified to US Standards • Ex db IIC T5 Gb • Class I, Zone 1, AEx db IIC T5 Gb
<i>International IECEx / ATEX *</i>	<ul style="list-style-type: none"> • II 2G Ex db IIC T5 Gb • Sira 17ATEX1303X • IECEx CSA 17.0034X

*** For ATEX / IECEx / CSA / UL and EU Declaration of Conformity certificates refer to www.arjayeng.com**

SPECIFIC CONDITIONS OF USE FOR HAZARDOUS LOCATION
(denoted by X after the certificate number)

1. Process temperature for the standard and heavy duty probes are -60°C to +200°C and for flexible probe is -60°C to +100°C. It is end-user's responsibility to ensure that the ambient around the Capacitance Controller and ARJAY Probe does not exceed the permitted ambient of +55°C.
2. The maximum process pressure is 1500psi/ 10342KPa.
3. Only approved certified entry devices shall be used.
4. Flameproof joints are not permitted to be repaired in the field. If the flamepath is damaged, the enclosure is to be removed from service and replaced with a new enclosure.

Model: 28aaa-bbb-c -d

Model: 28aaaW-bbb-c -d



Where:

aaa	bbb	c	d
80*	LT*	1 = 100-240VAC, 50/60Hz	4 = Ordinary Location Without Window, North America
81*	LS	2 = N/A	5 = Ordinary Location With Window, North America
82	OWS	3 = 12 VDC	6 = Explosion Proof Without Window, North America
80W*	OWI*	4 = 24 VDC	7 = Explosion Proof Without Window, ATEX, IECEx, North America
81W*	CAP*		8 = Explosion Proof With Window, ATEX, IECEx, North America
82W	FCM*		
	FCS		
	IFA		

Where: W = Window Option

* 2880, 2881, 2880W & 2881W available for these models only.

2.0 USE HAZARD INFORMATION

 CAUTION	Indicates a potentially hazardous situation that may result in minor or moderate injury.
 WARNING	Indicates a potentially or imminently hazardous situation which, if not avoided, could result in death or serious injury.
 DANGER	Indicates a potentially or imminently hazardous situation which, if not avoided, will result in death or serious injury.
NOTICE	Indicates a situation which, if not avoided, may cause damage to the instrument. Information that requires special emphasis.

3.0 INSTRUMENT OVERVIEW

The Arjay Model 2882-FCS Foam Control Switch provides two independent alarm relays for monitoring and control of foam in tanks, sumps and vessels.

The Arjay system has an active capacitance probe that is inserted into the vessel. As the foam level approaches or changes around the probe, the capacitance reading of the probe increases or decreases. The controller relays are calibrated to alarm at user determined levels of foam on the probe.

The probe mounted controller monitors the capacitance change of the probe and activates the relay contacts for use with alarms, pumps, valves, defoamer sprayers.

The complete 2882-FCS system consists of the probe and the 2882 controller. The standard probe is constructed of a Teflon coated probe.

Probes can be inserted vertically, horizontally, or angled into the tank. The sensor does not differentiate between liquid and foam. This system is designed to alarm for foam presence in a normal air condition.

On vertical and angled probes, the two relays can be set at the same or different levels. Each relay also has a differential setpoint to allow the relay to activate at one level and de-activate at a different level. This is similar to a latching format which can cycle a valve or control action between two points through the use of only one relay. For example, the defoamer spray can be activated at a high point and held on until the foam reaches a desired lower point.

On a horizontal insertion, both relays are calibrated to the same setpoint.

For single point high foam level applications, it is typical for both relays to be calibrated without bringing the foam level up to a specific alarm point. For example, in a high alarm application, the controller can be calibrated to air. An alarm will occur when the foam approaches and begins to cover the probe.

Models are available for use in General Purpose non-hazardous (Ordinary Location) areas as well as Hazardous Location use.

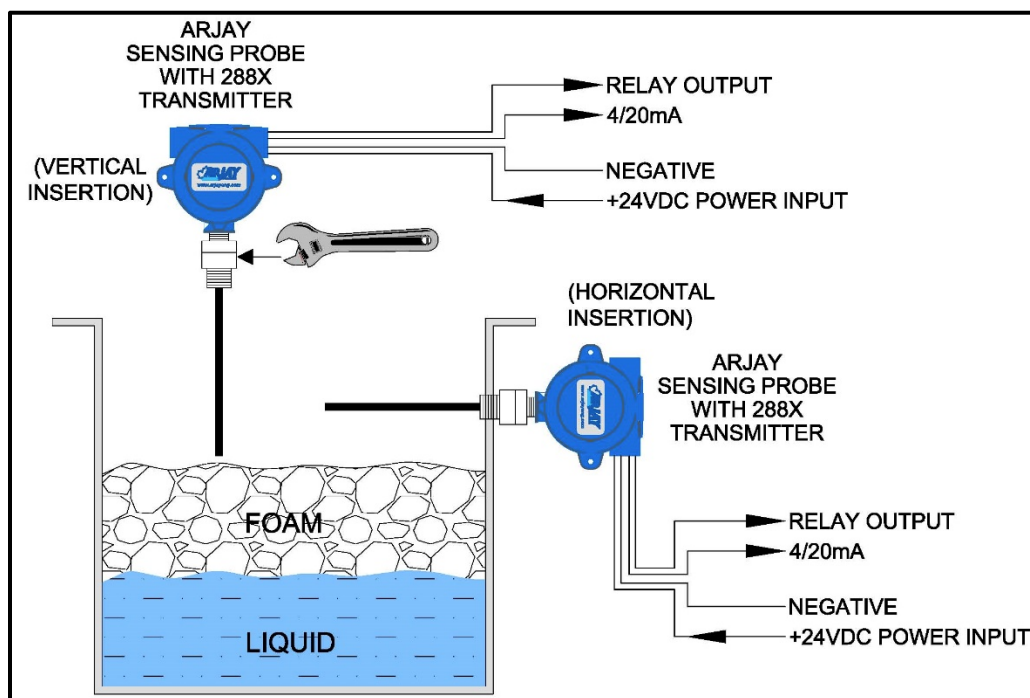

Figure 1 – Typical 2882-FCS Foam Control Application

3.1 Features

- Microprocessor based RF capacitance Foam Control Switch
- Two Differential Alarm relays (SPDT, 3A @ 250VAC)
- 4mA = Normal and 20mA = alarm output
- Modbus protocol via RS-485 for access by Arjay handheld, Central Access Panel or compatible system
- Local single point Auto calibration or remote calibration via network
- User specified custom features may be added by contacting Arjay Engineering Ltd.

3.2 Model Number Table

MODEL	DESCRIPTION
2882-FCS	PROBE MOUNTED 4/20mA (NON-ISOLATED) C/W RELAYS
2882W-FCS	PROBE MOUNTED 4/20mA (NON-ISOLATED) C/W RELAYS – WINDOW MOUNT

4.0 INSTALLATION

NOTICE	If any damage to the instrument is found, please notify an Arjay Engineering representative as soon as possible prior to installation.
NOTICE	Qualified Personnel must undertake all installations.

 WARNING	EXPLOSION HAZARD – DO NOT OPEN WHEN ENERGIZED.
 WARNING	DO NOT OPEN WHEN EXPLOSIVE ATMOSPHERE IS PRESENT

 WARNING	If the equipment is used in a manner not specified by the manufacturer, the protection provided by the equipment may be impaired.
--	---

4.1 Probe Mounted Controller Installation

Choose the mounting location in accordance with good instrument practice. Extremes of ambient temperature and vibration should be avoided (see specifications and installation drawing).

Due to static buildup during shipment the probe is left disconnected from the electronics. Make sure probe connector is installed into TB6 as per figure 3.

NOTICE	The controller operates in a Failsafe Mode (factory default) <i>This means that the relays are in an energized state during normal operation. The N.O. relay contact will be held closed and the N.C. relay contact will be held open during a normal condition. This will allow the relay to return to its non-energized (shelf) state during an alarm, fault or power failure condition. Wire accordingly.</i>
---------------	--

NOTICE	Maximum Conduit size for installation size is ¾” FNPT.
---------------	---

 CAUTION	The <u>Internal</u> ground screw provided in this enclosure must be used for equipment grounding connection. The <u>External</u> ground screw is provided for use only as a supplemental connection where required (or, permitted) by local codes or authorities.
--	--

4.2 Probe Installation

NOTICE

Read the following information ***before*** installation.

Standard probe entry into a tank is via a 3/4" NPT opening (standard probes) or 1" NPT opening (heavy duty probes). Flanges and concentric shields are available as options. The entrance configuration may vary depending on the application requirements.

TO SCREW IN THE PROBE (THREADED ENTRY) USE A WRENCH ON THE LOWER FITTING ONLY. The probe fittings are compression type with Teflon ferrules assembled by applying torque between the two sections. The fittings are sealed at the factory to provide a compression seal capable of withstanding pressure up to 1500 psi / 10342kPa. Once opened they cannot be reassembled without new ferrules.

NOTICE

Install the probe with care. Teflon sheath is used to electrically isolate the metal probe from the liquid. Damage causing leaks may cause reading errors.

NOTICE

The controller junction box should be mounted above the water surge level and in protected area.

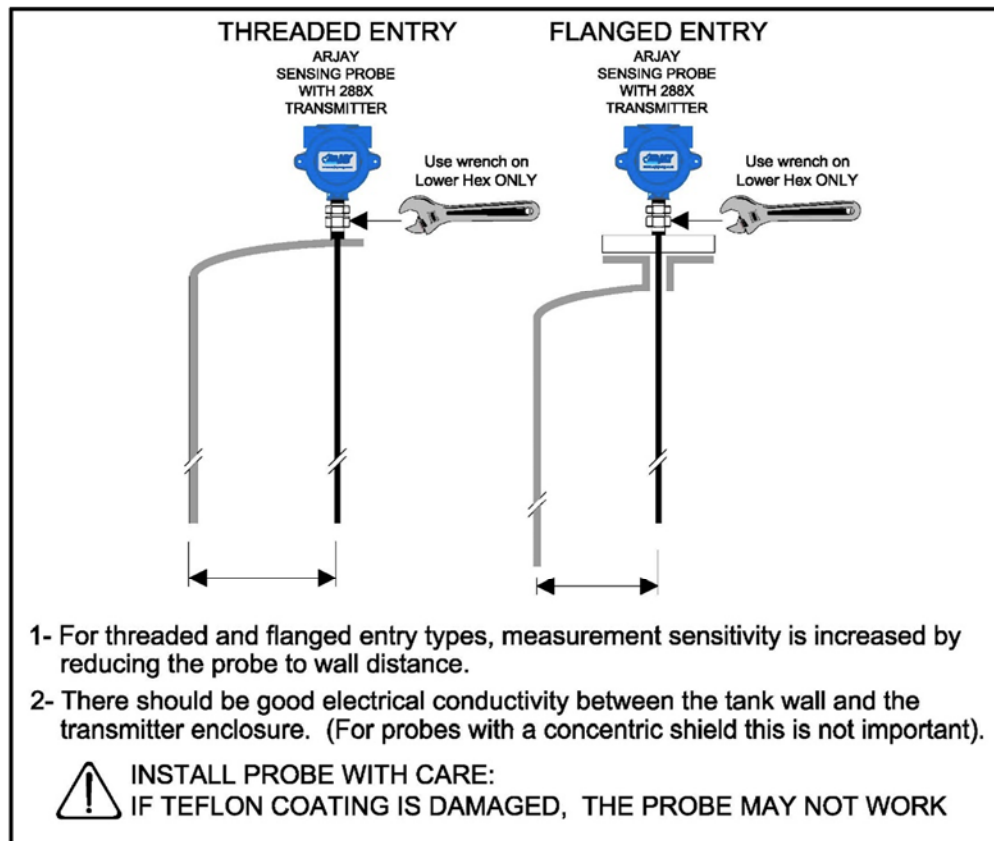

Figure 2 – Probe Installation

5.0 CONTROLLER OVERVIEW

See specific drawing(s) attached to this manual for more detail

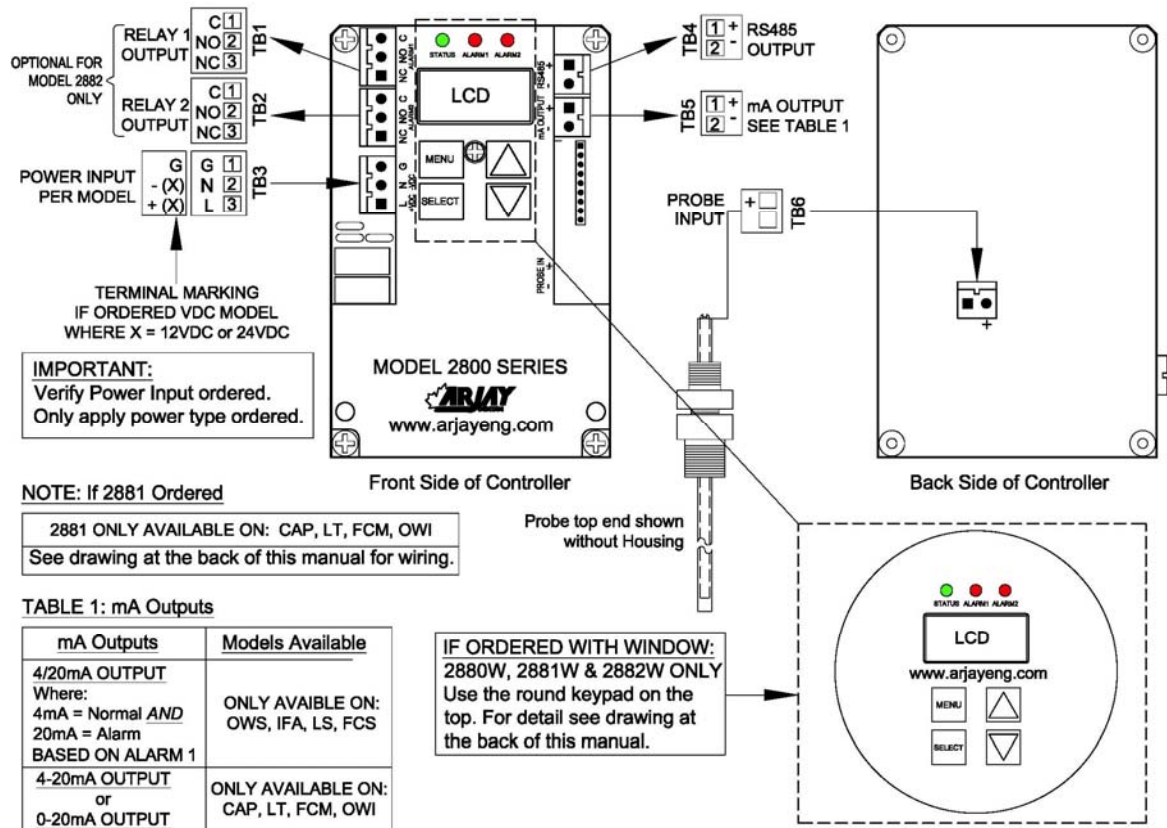

Figure 3 – Controller Overview

TB1/TB2 - Relay Output

2 SPDT relay, Dry Contacts are 3A @ 250 VAC (Resistive), selectable failsafe or non-failsafe, selectable high or low acting alarm, programmable time delay: 0 – 600 seconds

NOTICE

The controller relays are factory set in a Failsafe mode.

TB3 - Power Input

Power input as per Model. Check if ordered AC or DC. Earth ground is connected to Primary ground screw inside of enclosure.

TB4 - Network Output

Connect RS485 + and – to the network D+ and D-.

TB5 - mA Output

For OWS, IFA, FCS & LS models only:

The 4/20 mA is a sourced output referenced to Ground. It is not loop powered.
4mA = Normal 20mA = Alarm

For CAP, LT, FCM & OWI models only:

The 4-20mA is a sourced output referenced to Ground. It is not loop powered.

TB6 - Probe Input

Probe input is wired by the factory. The terminal block is disconnected during shipment for static reasons and has to be re-connected during installation. Probe wire is connected to “+” terminal of TB6.

5.1 Input / Output Terminal Specification

Input Terminals – Power Source					
Terminal ID	Overvoltage category	Rated Voltage (V)	Rated Current/power (A/W/VA)	— HZ or DC	Specified Mains fluctuation
TB3	II	100-240V	150mA	50/60Hz	± 10%
TB3	II	12 OR 24V	250mA	DC	+15% -10%

Input Terminals – Measuring Circuits					
Terminal ID	Function	Measurement Category	Nominal a.c. or d.c line to neutral voltage / if CAT I, Max. transient overvoltage Ut	Nominal a.c. or d.c current	Rating of insulation required for external circuit
TB6	Frequency	I	N/A	--	DI * or RI**
TB4	RS485 Communication	I	5V, 5mA / 0	--	DI * or RI**

* Double Insulation

**Reinforced Insulation

Output Terminals					
Terminal ID	Function	Isolation or protection	Rated V, A	Max. V, A	Load type and nominal
TB1	Load	Relay	3A Contact @250VAC	--	--
TB2	Load	Relay	3A Contact @250VAC	--	--
TB5	Current	Isolator(optional)	- 18V,20mA, 900Ω - 9V, 20mA, 450Ω	50mA @18V	--

5.2 Permanent Power Connection (AC Powered Models Only)

- 1) Connection to the building wiring system shall be in accordance with the Canadian Electrical Code (CEC), Part 1 in Canada, the National Electrical Code, ANSI/NFPA 70 in the USA, or the local electrical codes of the country where the equipment is being installed.
- 2) A disconnecting device is required. The disconnecting means shall disconnect all current-carrying conductors.
- 3) 15A circuit breaker or equivalent fuse is required.
- 4) An external switch or breaker shall be in close proximity to the equipment and within easy reach of the operator. The switch shall be marked as the disconnecting device for the equipment and include the symbols to its "ON" and "OFF" positions using the following symbols:





- 5) The wiring for AC power should be minimum 18 AWG / 300V or as required by local / country codes.
- 6) After field wiring, the primary wires must be secured to the enclosure by tie-wraps to maintain the separation from the signal wires.
- 7) Wiring diagram for permanent connection: See drawings at the back of this manual.
- 8) Use copper conductors only.

5.3 Glossary Of Symbols

	Attention, consult accompanying documents <i>Attention, veuillez consulter les documents ci-joints.</i>	
	Primary Protective Earth Ground <i>Primaire de terre de protection</i>	
	Secondary Earth Ground <i>Mise à la terre de secondaire</i>	
	Direct Current (DC) <i>Courant continu</i>	
	Normally closed relay contacts <i>Contacts Repos</i>	L
	Power on <i>Marche (mise sous tension)</i>	G
		N
		Neutral <i>Neutre</i>
		Fuse <i>Coupe-circuit; fusible</i>
		Normally open relay contacts <i>Contacts travail</i>
		Power off <i>Arrô (mise hors tension)</i>
		Live <i>Sous tension</i>
		Ground <i>Terre</i>

6.0 STARTUP AND CALIBRATION

6.1 Startup

 WARNING	EXPLOSION HAZARD – DO NOT OPEN WHEN ENERGIZED.
 WARNING	DO NOT OPEN WHEN EXPLOSIVE ATMOSPHERE IS PRESENT

Check that the power wiring and probe are wired in accordance with the electrical installation drawing. Connect the probe terminal block TB6 as per figure 3.

Power On the unit. Allow a 1 hour warm-up period before calibrating.

The Status LED on the controller circuit board should be green. A red Status LED indicates a fault condition. If red, check the Troubleshooting section.

The LCD will scroll to the normal operating display. See section 10.0 Menu Flow Chart.

NOTICE	An instrument setup and field calibration is required on initial power up. See section 6.3 for controller setup and section 6.4 to calibrate the transmitter.
---------------	--

6.2 Menu Flow Chart Background Information

The control setup, diagnostics, and calibration are accessed using the display and keypad on the controller. The Flow Chart in Section 10.0 provides an overview to the various menus and features. Keep a copy of the flow chart at hand when accessing the internal controller features.

Below is a description of the menu functions.

6.2.1 Menu Short Form

Since the 288X controller has a small LCD, some menu description may be in short form. The following are the menu descriptions:

Short Form	Description
<i>Diags:</i>	<i>Diagnostics</i>
<i>Cal Pts:</i>	<i>Calibration points</i>
<i>Auto Cal:</i>	<i>Auto calibrate</i>
<i>Man Cal:</i>	<i>Manual calibrate</i>
<i>Cal Ok:</i>	<i>Calibrate ok</i>
<i>Cal Err:</i>	<i>Calibrate err</i>
<i>mA out:</i>	<i>mA output</i>
<i>mA Span:</i>	<i>mA output span</i>
<i>Sec:</i>	<i>Seconds</i>
<i>ALRM CAL:</i>	<i>Alarm Calibration</i>
<i>Cal:</i>	<i>Calibration point</i>
<i>Net ID</i>	<i>Network Identification</i>

Short Form	Description
<i>SENSTVTY:</i>	<i>Sensitivity</i>
<i>A1:</i>	<i>Alarm relay 1</i>
<i>A2:</i>	<i>Alarm relay 2</i>
<i>Alrm:</i>	<i>Alarm</i>
<i>Alrm Lvl:</i>	<i>Alarm level</i>
<i>Diff Hi:</i>	<i>Differential Hi alarm set value</i>
<i>Diff Lo:</i>	<i>Differential Lo alarm set value</i>
<i>Alrm Del:</i>	<i>Alarm Delay</i>
<i>^SP:</i>	<i>Relay Setpoint Hi action</i>
<i>vSP:</i>	<i>Relay Setpoint Low action</i>

6.2.2 Menu Description

The 2882-FCS controller will display the **Normal** in its normal condition and **Alarm** during an foam condition.

The 2882 controller has a password protect feature. The default password is 2000. See section 6.3.1 “Password” if wish to have personal password.

From the main menu, you can select **Cal Only, View, and Change**.

Cal Only allows a one point calibration based on a factory or custom pre-configuration. In most applications, this is the only menu item required after the initial power-up. The calibration is required at site after power up or anytime a component or sensor is changed out. A password is required to enter this and is described in the calibration section.

View allows an operator to view the **Calibration** setpoints in pF, the **Alarms** settings such as low or high action, failsafe or non-failsafe and the 0-600 second delay, the **Diagnostics** of raw readings and the **Setup** values such as mA output and ID address. This can be viewed without a password and without risk of changing any values. This information may be requested during technical assistance inquiries.

Change is password protected and allows an operator to change the configuration set-up values indicated in the View. Changes will be required for the initial setup of relay setpoints, delays, span etc. or to re-set the values to the factory default.

6.2.3 Data Entry

Data Entry

Press <▲> / <▼> key to increase / decrease the digital value.

Press <SELECT> key to move the cursor.

Press <MENU> key to abort certain screens.

6.3 288X Controller Setup

Power up the 288X Controller. The status LED should be green. The LCD will scroll to the normal operating screen after a series of the following screens (each displays for 2 sec.). * It may read **Normal** or **Alarm** until a calibration is performed.

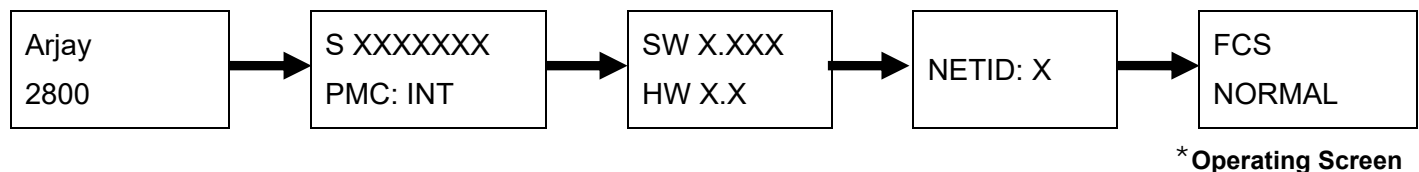

6.3.1 Setup And Network

Press and Hold the menu key to enter the main menu. Follow the Flow Chart procedure to access the **Change** menu. Toggle to access the Setup menu.

The 2882 Foam Control Switch Controller has the following setup parameters. These must be set up to the requirements of the application and can be accessed in the CHANGE menu. Follow through the flowchart in section 10.0 and input the settings as required.

1. Sensitivity

The sensitivity determines the amount of pF change required to cause an alarm. The factory default setting is 1.0 pF. The most sensitive setting is 0.1 pF. Increasing the pF value will increase the amount of foam required to cause an alarm. Since different foam may have different dielectrics

pF to mm of liquid level relationship cannot be factory determined. If this is changed in the field, it should be tested to confirm an alarm.

2. Alarm Calibration above or below setpoint

This setting advises the Level Switch if the calibration setpoint is above or below the alarm condition. For high alarm applications, the alarm condition is above calibration setpoint. This indicates that the pF value must increase above the setpoint to activate the alarm. For low alarm applications, the alarm condition is below the calibration setpoint. This indicates that the pF value must decrease below the setpoint to activate the alarm. The factory default is High Alarm = ^SP.

3. Defaults

Factory settings are pre-configured into the unit based on the most typical set-up required for this application. This provides for a quick and easy calibration at site but can be changed to suit specific applications. If the setup has been field changed, selecting this will change back to the factory defaults.

4. NET ID

The ID number is used only for network applications. To communicate on a network, each controller must have a unique ID number. The factory default ID number is 1.

NOTICE

If multiple units on a network have the same address, network errors will result.

5. Filter

Data filtering is used to smooth data from a sudden change and minimize fluctuating readings. For example, a 5 second setting means the calculated value of the capacitance and resulting values of pF will start to respond immediately but will take 5 seconds to reach their final values. The factory default is 0 to provide an immediate and active response. This can be user selected from 0 - 99.9 seconds.

6. Password

The unit is shipped with password "2000". The user can continue to use this password or may change to a personal password after installation. To change password go to "Change" menu and toggle down to "Setup" menu then to "Password". Press Select. Enter new password. The password "2000" is no longer available. Consult factory if new password has been forgotten.

6.3.2 Relay Setup Menu

Press and Hold the menu key to enter the main menu. Follow the Flow Chart procedure to access the **Change** menu. Toggle to access the Setup menu.

The 2882 FCS Controller has 2 relays (A1 and A2) that operate independently. The following parameters are available to set up each of the relays:

1. RELAY DELAY. Minimum time in seconds for an alarm to exist before the relays change to an alarm state. The relay alarm state depends on the Relay Action and Failsafe settings. The factory setting is 20 seconds to suppress false alarms due to sudden or intermittent flows or disturbances in front of the sensor.
2. RELAY ACTION. This determines if the Alarms LEDs should activate when the pF reading rises above or below the setpoint. The factory default is above the setpoint because the application of air to foam is an increase in capacitance.
3. FAILSAFE. Failsafe typically means that the relay is normally (when not in an alarm condition) held in an energized state. In an alarm condition, the relay is de-energized i.e. identical to when the instrument power is shut off. The rationale is that the alarm condition should match the Power Fail condition. Factory default is Yes.

Example Of Single Point Alarms (No Differential) Applications

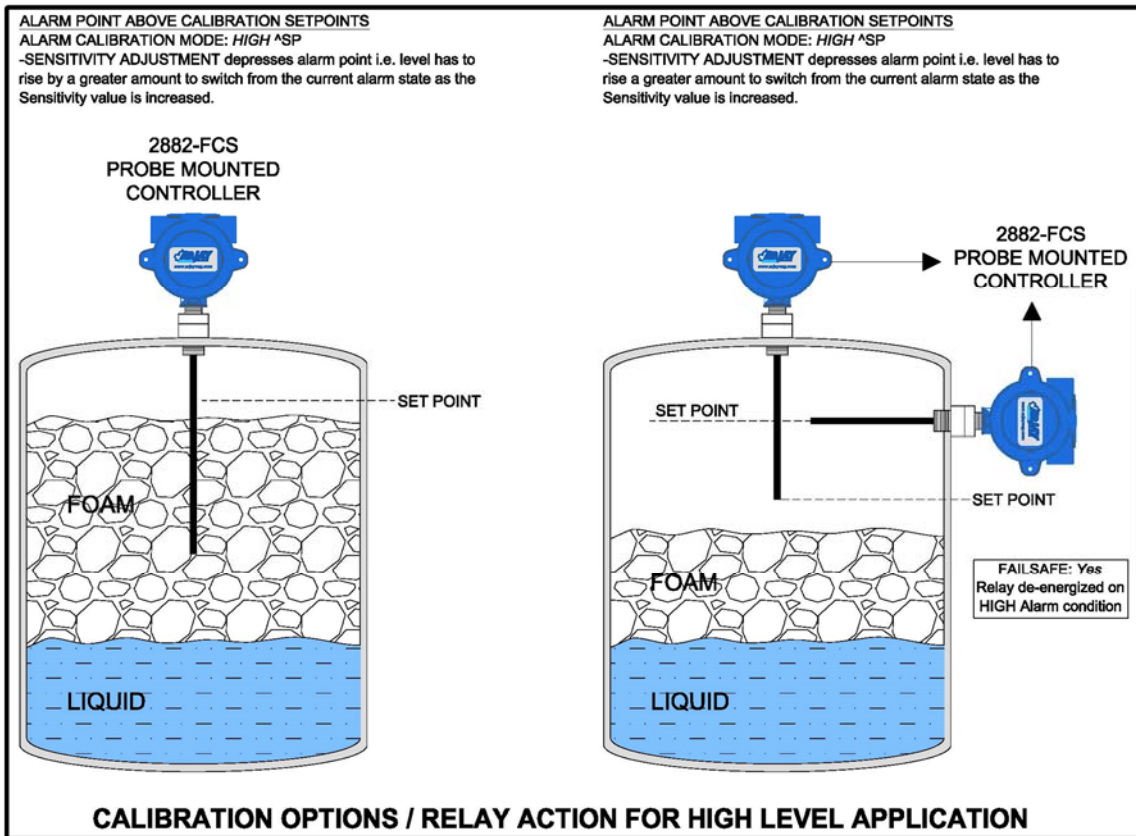

Figure 4 – No Differential Application – High Level

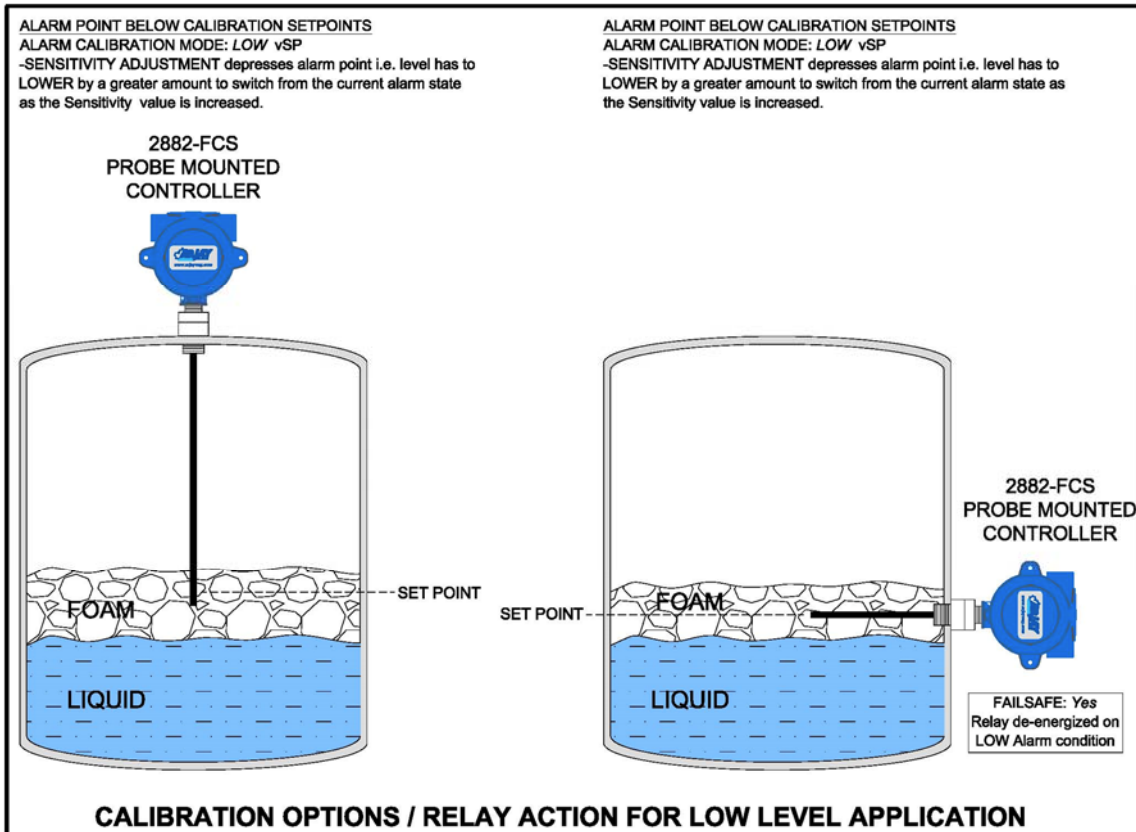

Figure 5 – No Differential Application – Low Level

6.4 288X Controller Calibration

6.4.1 Site Calibration

For a single point high foam alarm, the foam level may not need to be changed.

For a high alarm application, a *vertical* OR *horizontal* probe can be in air and well above the liquid or foam. The probe is calibrated to air and as the foam reaches the probe, it will alarm.

For a low alarm application, a *horizontal* probe can be fully submerged in foam during calibration. The probe is calibrated to the foam and as the foam interface drops below the probe, it will alarm.

However, on vertical probes, if the alarm setpoint is desired at a specific point along the length the probe, or if the differential control is being used, a product level change during calibration will be required.

The following are the basic steps for setting up two alarm points each with a HI/LO differential. Refer to the Flow Chart for a detailed set-up and calibration.

Check that the foam or liquid is at the desired level for calibration (ie. that the probe is in air for a typical high level alarm application).

Press and hold Menu key for 5 seconds to enter the main menu. The display will read the first menu item **Cal only**. Press select key, enter password "2000".

The display will read **Select Cal A1**. Press Select to calibrate the first setpoint of Relay 1. This can be either the HI or LOW point of the differential.

This display will read **A1 PT 1** with a pF reading of the probe displayed. Press select to acknowledge and then press select to confirm the new calibration.

The display will read **A1 PT 2** with a pF reading. This is the second point for Relay 1. For a single point alarm without differential this will be the same point. Press select to accept this second point. If differential control on the relay is required, change the product level to the new setpoint level and press Select.

The menu will now guide you through setting up the second relay (A2) setpoints.

When complete, Select **EXIT**.

This will get you back to the main menu of "CAL ONLY". Press arrow down until you get to "EXIT" in order to get back to main screen OR go to "Change" if different relay configurations are required.

***THIS COMPLETES THE SETUP & CALIBRATION PROCEDURE FOR THE
2882-FCS PROBE MOUNTED FOAM CONTROL SWITCH***

7.0 CONTROLLER NETWORK

The *28XX series Transmitter may be monitored and calibrated via RS-485 protocol compatible digital communications.

Typical features are:

1. Ease of wiring in multiple level point monitoring:

Up to 255 of Arjay *28XX Series transmitter or monitor may be connected together in a daisy chain (2 wire communication plus power wiring) connection to an Arjay Remote Access monitor or customer control system which allows viewing data and setup of any of the transmitters on the network. The 4-20mA output may still be used if necessary.

2. Setup for the *28XX for network operation:

Each *28XX controller must have a unique number to connect in a network system. See section 10.0 Menu Flow Chart, CHANGE menu for details to change the ID number.

***Where "XX" = 80, 81 or 82**

7.1 MODBUS Configuration

Parameter settings: 9600 Baud Rate; Even Parity, 8 Data Bits and 1 Stop Bit.

Wiring connection: RS485 (+) connect to D+; RS485 (-) connect to D-.

7.2 2800 Series MODBUS Register Mapping

REG	Zero Based	DESCRIPTION	TYPE	No. of Reg
40001	0	Serial Number	float	2
40003	2	Hardware Rev / Software Rev	byte	1
40004	3	Spare / Mode	byte	1
40005	4	Sensitivity A2 / Sensitivity A1	byte	1
40006	5	Instrument Status 1 / Instrument Status 0	byte	1
40007	6	Model type / Modbus ID address	byte	1
40008	7	Relay2 Setup / Relay 1 Setup	byte	1
40009	8	Password	int	1
40010	9	XA "A" cal parameter	float	2
40012	11	XK "K" cal parameter	float	2
40014	13	XC "C" cal parameter	float	2
40016	15	Filter	float	2
40018	17	Slope - pF per% level	float	2
40020	19	Offset - pF for empty vessel	float	2
40022	21	mA output span value	float	2
40024	23	mA output zero value	float	2
40026	25	mA output Trim Slope value	float	2
40028	27	mA output Trim Offset value	float	2
40030	29	Cal1 PV: Level calibration: 1st level point in %	float	2
40032	31	Cal2 PV: Level calibration: 2nd level point in %	float	2
40034	33	Cal1 pF: Level calibration: 1st capacitance value in pF	float	2
40036	35	Cal2 pF: Level calibration: 2nd capacitance value in pF	float	2
40038	37	Relay 1 : Differential High Alarm.	float	2
40040	39	Relay 2: Differential High Alarm.	float	2
40042	41	Relay 1: Differential Low Alarm.	float	2
40044	43	Relay 2: Differential Low Alarm.	float	2
40046	45	Relay 1 On delay [seconds]	int	1
40047	46	Relay 2 On delay [seconds]	int	1
40048	47	mA Analog Output	float	2
40050	49	Osc. Frequency	float	2
40052	51	Frequency	float	2
40054	53	Capacitance	float	2
40056	55	Filtered Capacitance	float	2
40058	57	Level	float	2
40060	59	Compensated pF for point level if enable Temperature compensation	float	2
40062	61	Temperature in mV	float	2
40064	63	Temperature in degree C	float	2
40066	65	Compensation factor: percent per degree	float	2
40068	67	Temperature at Calibration	float	2
40070	69	Temperature offset [mV at 0 dC]	float	2
40072	71	Temperature slope [mV per dC]	float	2
40074	73	Alarm 1 differential Off value	float	2
40076	75	Alarm 2 differential Off value	float	2

8.0 MAINTENANCE

There is no routine cleaning required for this controller.

9.0 TROUBLESHOOTING

CONDITION	DO THIS
1. Status LED is OFF and the LCD display is off	Check the power to the unit. If the unit is a 12VDC or 24VDC model, check the external source and polarity is correct. If the unit is a 100-240VAC model, then check the Line, Neutral and Ground wiring is correct.
2. If the status LED is RED	This indicates a major error such as memory failure, no probe signal etc. Check the following: <ul style="list-style-type: none"> • Make sure the probe wiring is correct and plugged into controller. • Microprocessor may have lost its parameters due to a power surge in the line. Go to Diagnostic in view Menu (see section 10.0 Flow Chart) to check the Calibration values, frequency and capacitance values then, call Arjay Technical Support.
3. No mA output OR incorrect mA output.	<p>IMPORTANT: THE UNIT SOURCES mA OUT FROM THE mA OUTPUT TERMINAL. <u>THIS TERMINAL SHOULD NOT BE CONNECTED TO +24V.</u> IT IS NOT A 2 WIRE mA TRANSMITTER. See Figure 3 for Electrical hookup details.</p> <ul style="list-style-type: none"> • Disconnect external wires from mA output and measure with mA Meter. • Check the mA output Action (direct or inverse) and mA output Span are set as desired. See section 10.0 Flow chart / Change menu. • If the mA output still does not match the level, then call Arjay Technical Support.
4. Level reading is not correct	<ul style="list-style-type: none"> • Make sure probe is properly grounded to Tank. • Ensure that there is a parallel ground reference with probe via Tank wall or concentric shield. • Go to View Menu, then select CAL. Write down the %level and pF reading of each CAL point. Go to DIAG menu and verify existing pF reading. If pF reading is within range of CAL point then unit can be trimmed by Entering a new CAL point in manual CAL under change menu. If pF way out of range then check what changes may have occurred since initial CAL. E.G. different material, new location for probe, Temperature.
5. CAL Error No Change	<ul style="list-style-type: none"> • Make sure blue wire from probe end is connected to TB6 terminal plug and connected to the 288X electronics. • Make sure level is changing in tank when performing 2nd Cal point.

ARJAY ENGINEERING TECHNICAL SUPPORT

(800) 387-9487

+1 (905) 829-2418

www.arjayeng.com

10.0 FLOW CHARTS

NORMAL OPERATING DISPLAY

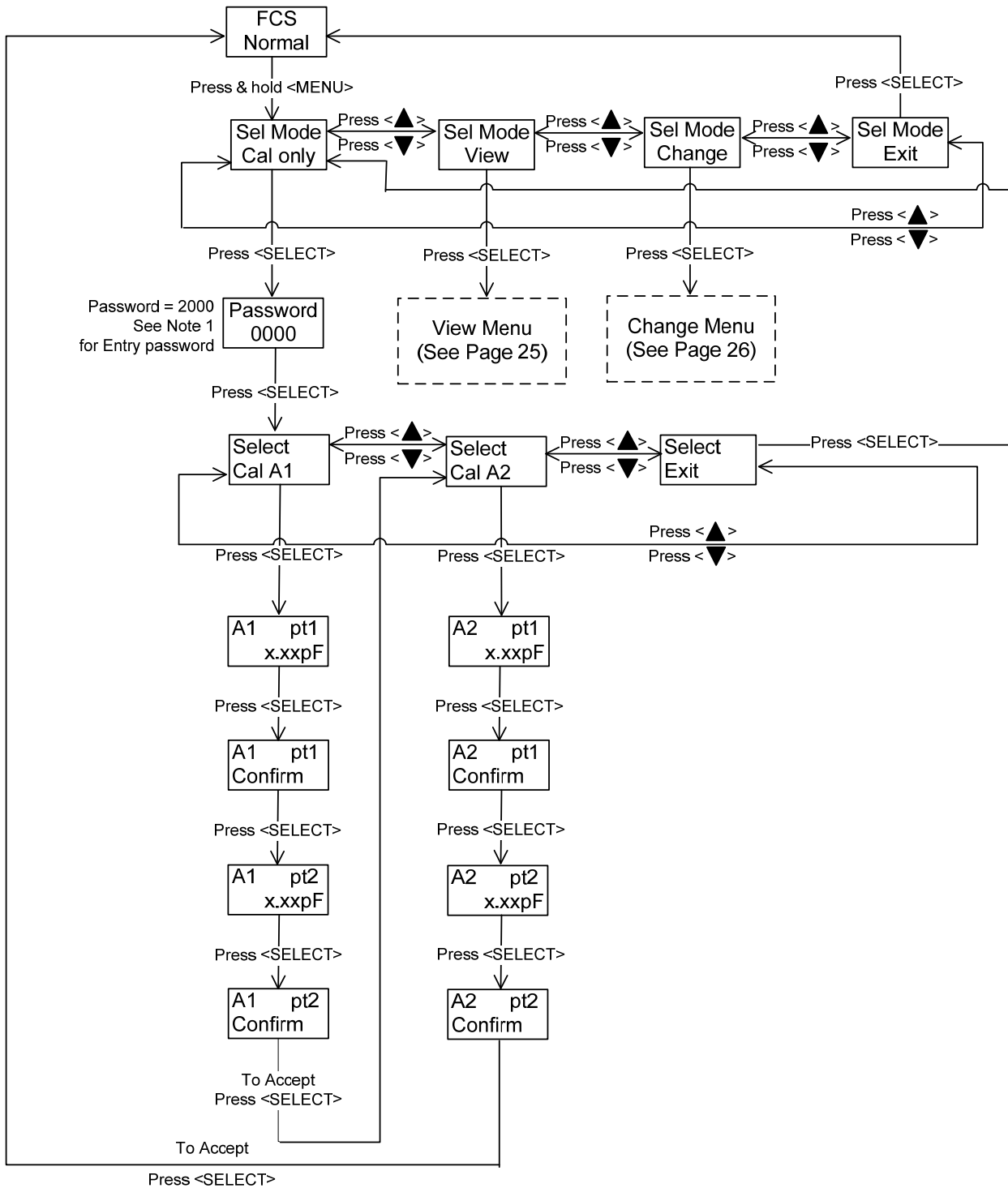

Note 1: Data Entry
 Press <▲> / <▼> key to increase / decrease the digital value.
 Press <SELECT> key to move the cursor.
 See section 6.3.1 step 7 if password has changed.

CHANGE MENU

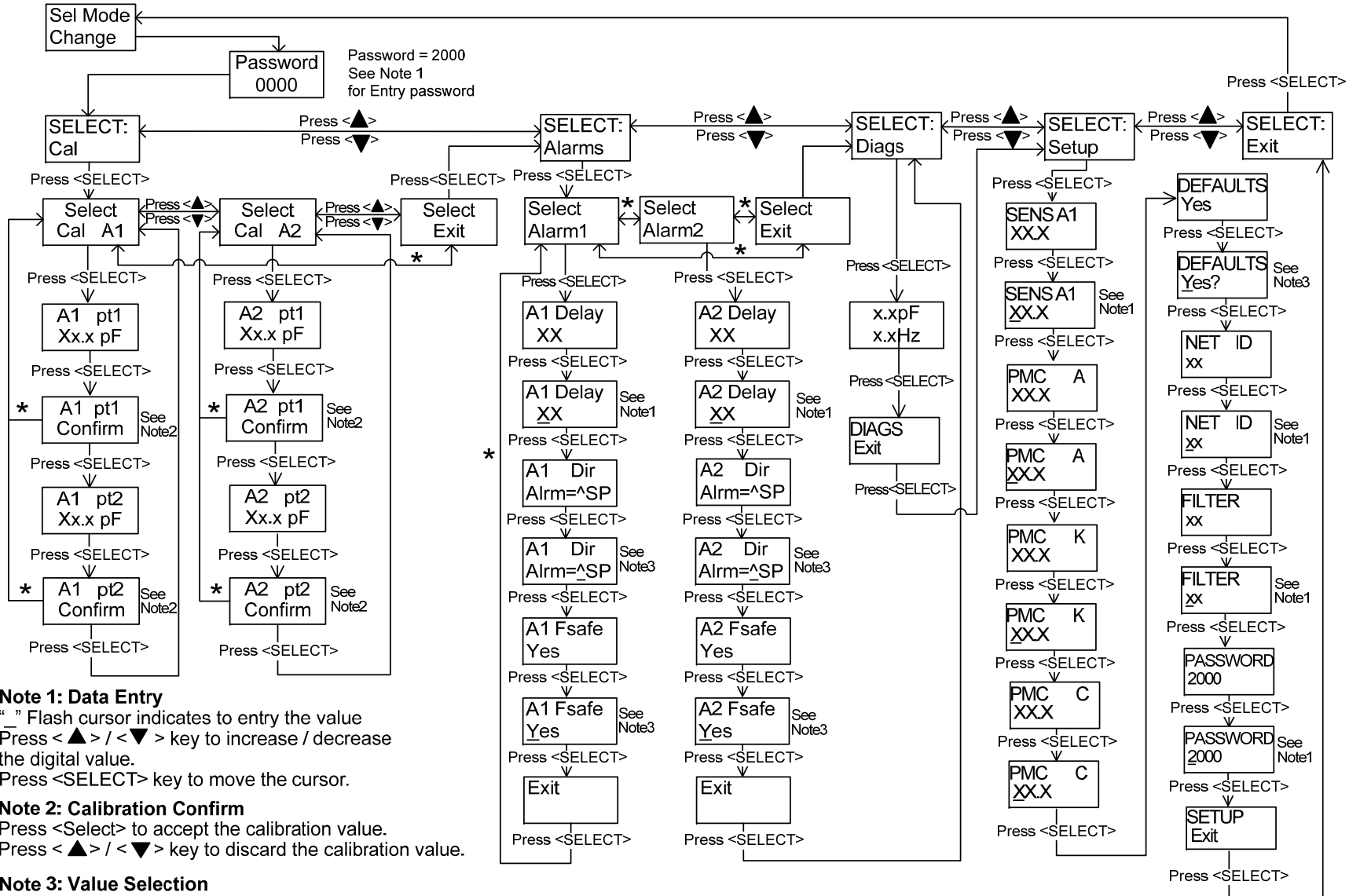

Note 1: Data Entry

“ _ ” Flash cursor indicates to enter the value
 Press <▲> / <▼> key to increase / decrease the digital value.
 Press <SELECT> key to move the cursor.

Note 2: Calibration Confirm

Press <Select> to accept the calibration value.
 Press <▲> / <▼> key to discard the calibration value.

Note 3: Value Selection

“ _ ” Flash cursor indicates to select the value
 Press <▲> / <▼> key to select the desired value.

Note 4: Password

See section 6.3.1 step 7 if password has changed.

* = Press <▲>
 Press <▼>

THIS PAGE INTENTIONALLY LEFT BLANK