



MODELS:
2852T-ILA
REMOTE MOUNTED
INTERSTITIAL TANK LEAK ALARM



USER MANUAL (REV: 3.2)

ARJAY ENGINEERING LTD.		
2851 Brighton Road Oakville (Toronto), Canada L6H 6C9	TEL: ++1 (905) 829-2418 FAX: ++1 (905) 829-4701 NORTH AMERICA: 1-800-387-9487	WEBSITE: www.arjayeng.com EMAIL: arjay@arjayeng.com

THIS PAGE INTENTIONALLY LEFT BLANK

TABLE OF CONTENT

NOTICE

Please read the Installation Notes (4.0) prior to locating and mounting the instrument.

1.0	SPECIFICATION	4
2.0	USE HAZARD INFORMATION.....	7
3.0	INSTRUMENT OVERVIEW.....	8
3.1	Features	9
3.2	Model Number Table	9
4.0	INSTALLATION.....	10
4.1	Remote Mounted Controller Installation	10
4.2	Probe Installation.....	11
5.0	CONTROLLER OVERVIEW.....	13
5.1	Input / Output Terminal Specification	14
5.2	Permanent Power Connection (AC Powered Models Only)	15
5.3	Glossary Of Symbols.....	15
6.0	STARTUP AND CALIBRATION.....	16
6.1	Startup	16
6.2	Menu Flow Chart Back Chart Background Information	16
6.2.1	Menu Short Form.....	16
6.2.2	Menu Description.....	17
6.2.3	Data Entry.....	17
6.3	2852 Controller Setup.....	17
6.3.1	Setup And Network.....	17
6.3.2	Relay Setup Menu	18
6.4	2852 Controller Calibration	19
6.4.1	Site Calibration	19
7.0	CONTROLLER NETWORK.....	20
7.1	MODBUS Configuration	20
7.2	2800 Series MODBUS Register Mapping	21
8.0	MAINTENANCE.....	22
9.0	TROUBLESHOOTING.....	23
10.0	FLOW CHARTS.....	24

TABLE OF FIGURES

FIGURE 1 – PROBE INSTALLATION (FLEXIBLE)	11
FIGURE 2 – PROBE INSTALLATION (RIGID)	12
FIGURE 3 – CONTROLLER OVERVIEW.....	13

1.0 SPECIFICATION

Specifications are subject to change without notice

Specification	Details
Power Input: (Specify voltage at time of Order)	12VDC +15% /-10% or 24VDC +15% /-10%, 250mA maximum 100VAC – 240VAC +/- 10%, 50/60 Hz, 150mA maximum Note: DC input models must be supplied by Limited Energy power source. Limited Energy means compliance with one of the following requirements: <ul style="list-style-type: none"> - Class 2 circuit according to Canadian Electrical Code, Part, I, C22.1; - Class 2 circuit according to National Electrical Code, NFPA-70; - Limited Power Supply (LPS) according to IEC 60950-1; - Limited-energy circuit according to IEC 61010-1.
Connections to mains supply	Permanent (for AC/DC model)
User Interface: Display & Keypad Communication Interface:	Two line LCD display, Alarm status LEDs and Keypad for select menu or enter values Modbus (RS485)
Relays / Analog Outputs: Relay Outputs mA Signal Output	2 SPDT relays, Dry Contacts are 3A @ 250 VAC (Resistive), selectable failsafe or non-failsafe, selectable high or low acting alarm, programmable time delay: 0 – 600 seconds , 0-100% differential 4mA during Normal and 20 mA during an alarm condition, 900 Ohms max (24VDC Power) OR 450 Ohms max (12VDC Power).
Instrument Performance: Measuring Range Accuracy Resolution Calibration	0 - 5000 pF (Most applications are 100pF to 1000pF) 0.2% of full scale pF 0.004% at 1000pF Single point Auto calibration
Environmental: Operating conditions Ambient Temperature Process Temperature Maximum Process Pressure Relative humidity Altitude Installation Category Pollution Degree Equipment mobility	Continuous -20 °C to +55 °C controller -40 °C to +55 °C PMC2800 pulse card in probe junction box -60 °C to +200 °C Standard or Heavy Duty Teflon Probe -60 °C to +100 °C Flexible Tefzel Probe 1500 PSI / 10342 kPa 0 to 95% (non-condensing) ≤2000 m II 2 Fixed

Specification	Details
<p>Mechanical Specification:</p> <p>Protection Degree – Controller Enclosure</p> <p>Protection Degree – Probe Junction Box</p> <p>Options on Controller Enclosure:</p>	<p>Refer to Dimensional Drawing</p> <p>Type 4 / IP65 Painted Steel (Blue) Type 4x / IP66 Polycarbonate (Gray) Type 4x / IP66 316 Stainless Steel</p> <p>IP65</p> <p>Buzzer Pilot Light OR Strobe/Beacon Intrinsic Safety Barrier Custom alarms</p>
<p>2800 Series Controller Certification</p> <p>Ordinary Locations:</p>	<ul style="list-style-type: none"> • UL file number: E343390 • UL / IEC 61010-1, 2nd Edition, 2008/10/28 (Electrical Equipment for Measurement, Control, and Laboratory Use; Part 1: General Requirements) • CAN/CSA-22.2 No. 61010-1, 2nd Edition, 2008/10/01, (Electrical Equipment for Measurement, Control, and Laboratory Use; Part 1: General Requirements) • CE: UL / IEC 61010-1; IEC / EN 61000-4; ISO 9001:2008
<p>Remote ILA Capacitance Probe Certification (Hazardous Locations)</p> <p><i>North America</i></p> <p><i>International IECEx/ATEX *</i></p> <p><i>Optional Intrinsic Safety *</i> (Zone 0, Div 1) for North America, IECEx/ATEX</p>	<ul style="list-style-type: none"> • CSA file number: 56812 • Class – 2258-02 – Process control equipment for Hazardous Locations • Class – 2258-82 – Process control equipment for Hazardous Locations – Certified to US Standards • Ex db IIC T5 Gb • Class I, Zone 1, AEx db IIC T5 Gb • II 2G Ex db IIC T5 Gb • Sira 17ATEX1303X • IECEx CSA 17.0034X <p>For certifications see PMC2800/PMC2800-TMP manual (Addendum 1) for more detail.</p> <p>Note: Must order Intrinsic Safety Barrier. Model: 28aaa-bbb-c-defg</p>

*** For ATEX / IECEx / CSA / UL and EU Declaration of Conformity certificates refer to www.arjayeng.com**

SPECIFIC CONDITIONS OF USE FOR HAZARDOUS LOCATION
(denoted by X after the certificate number)

1. Process temperature for the standard and heavy duty probes are -60°C to +200°C and for flexible probe is -60°C to +100°C. It is end-user's responsibility to ensure that the ambient around the Capacitance Controller and ARJAY Probe does not exceed the permitted ambient of +55°C.
2. The maximum process pressure is 1500psi/ 10342KPa.
3. Only approved certified entry devices shall be used.
4. Flameproof joints are not permitted to be repaired in the field. If the flamepath is damaged, the enclosure is to be removed from service and replaced with a new enclosure.



Model: 28aaa-bbb-c-defg

Where:

aaa	bbb	c	d	e	f	g
51*	LT *	1 = 100-240VAC, 50/60Hz	0 = No Housing	0 = No Light	0 = No Buzzer	0 = No Intrinsic Barrier
52	LS	2 = N/A	1 = Painted Steel blue (4)	1 = Red Pilot Light	1 = Buzzer	1 = Intrinsic Barrier
	OWS	3 = 12 VDC	2 = Polycarbonate (4X)	2 = Amber Beacon		
	OWI *	4 = 24 VDC	3 = Brushed 316SS (4X)	9 = other		
	CAP *					
	FCM *					
	FCS					
	IFA					
	ILA					

** 2851 available for these models only.*

2.0 USE HAZARD INFORMATION

 CAUTION	Indicates a potentially hazardous situation that may result in minor or moderate injury.
 WARNING	Indicates a potentially or imminently hazardous situation which, if not avoided, could result in death or serious injury.
 DANGER	Indicates a potentially or imminently hazardous situation which, if not avoided, will result in death or serious injury.
NOTICE	Indicates a situation which, if not avoided, may cause damage to the instrument. Information that requires special emphasis.

3.0 INSTRUMENT OVERVIEW

The Arjay Model 2852T-ILA Interstitial Tank Leak Alarm provides a means for detecting the accumulation of liquid in the interstitial space of double walled tanks and vessels. The Arjay probe has an active capacitance sensor at the probe tip that monitors the normally dry space around it. Liquids have a higher dielectric constant than the dry condition, which results in an increased capacitance reading when liquid accumulates and displaces the air.

The Arjay system has an active capacitance probe that is inserted into the vessel. As the material level changes around the probe, the capacitance reading of the probe increases or decreases. The controller output and relays are calibrated at user determined levels of product on the probe.

The remote mounted Arjay 2852 controller monitors the capacitance change of the probe and activates the relay contacts for use with alarms, pumps, valves, etc. The analog output and RS-485 Modbus communication are available for control interface.

The complete 2852T-ILA system consists of the probe, the PMC card and 2852 controller.

The standard ILA probe is constructed of a Flexible Tefzel coated cable with Flexible SS inactive sheath. The probe tip should be positioned at approximately the 7 o'clock position in cylindrical tanks or 20mm off the bottom of vertical tanks to avoid nuisance alarms from condensation. The active probe tip is 200mm long to increase sensitivity for both high and low dielectric liquids. The unit will alarm from an external wall leak of groundwater into the space or an internal wall leak of product into the space. The PMC card is mounted in a junction box at the top of the probe. The PMC card translates the capacitance signal from the probe into a frequency pulse, which can be transmitted up to one kilometer to the 2852 controller via 3-wire shielded cable.

The 2852T controller is to be located in General Purpose non-hazardous areas. The probe is rated for hazardous locations and requires explosion proof conduit when used within this classification. Alternatively the 2852T is available as an Intrinsically safe unit. Consult Arjay Engineering Ltd. for more detail.

3.1 Features

- Microprocessor based RF capacitance level transmitter
- Two Alarm relays (SPDT, 3A @ 250VAC) which operate together
- 4/20mA Alarm output where 4mA = Normal and 20mA = alarm output
- Modbus protocol via RS-485 for access by Arjay handheld, Central Access Panel or compatible system
- Local single point Auto calibration or remote calibration via network
- User specified custom features may be added by contacting Arjay Engineering Ltd.
- Temperature Compensation

3.2 Model Number Table

MODEL	DESCRIPTION
2852T-ILA-1	100-240VAC REMOTE MOUNTED 4/20mA (NON-ISOLATED) C/W 2 ALARM RELAYS
2852T-ILA -3	12VDC REMOTE MOUNTED 4/20mA (NON-ISOLATED) C/W 2 ALARM RELAYS
2852T-ILA -4	24VDC REMOTE MOUNTED 4/20mA (NON-ISOLATED) C/W 2 ALARM RELAYS

4.0 INSTALLATION

NOTICE	If any damage to the instrument is found, please notify an Arjay Engineering representative as soon as possible prior to installation.
NOTICE	Qualified Personnel must undertake all installations.



 WARNING	EXPLOSION HAZARD – DO NOT OPEN PROBE JUNCTION BOX WHEN ENERGIZED.
 WARNING	DO NOT OPEN WHEN EXPLOSIVE ATMOSPHERE IS PRESENT

 WARNING	If the equipment is used in a manner not specified by the manufacturer, the protection provided by the equipment may be impaired.
--	---

4.1 Remote Mounted Controller Installation

Choose the mounting location in accordance with good instrument practice. Extremes of ambient temperature and vibration should be avoided (see specifications and installation drawing).

The 2852T controller may be mounted up to one kilometer from the PMC card using a minimum 18 gauge, 3-wire SHIELDED cable (Belden 8770 or Equivalent).

Check the polarity of the + and - wiring between the controller and the PMC prior to powering on the unit; + to + and - to - to avoid damage. Connect the temperature compensation wire “T” to TB7. Shield of cable should be connected to secondary ground terminal marked as  (at controller side only). Incoming Earth ground should be connected to primary ground terminal marked  on sub plate.

NOTICE	<p style="text-align: center;">The controller operates in a Failsafe Mode (factory default)</p> <p><i>This means that the relays are in an energized state during normal operation. The N.O. relay contact will be held closed and the N.C. relay contact will be held open during a normal condition. This will allow the relay to return to its non-energized (shelf) state during an alarm, fault or power failure condition. Wire accordingly.</i></p>
---------------	---

NOTICE	Maximum Conduit size for installation size is ¾” FNPT.
---------------	--

NOTICE	To ensure proper operation and electrical safety, make sure the 2852 enclosure and the PMC junction box are electrically grounded.
---------------	--

 CAUTION	<p>The <i>Internal</i> ground screw provided in this enclosure must be used for equipment grounding connection.</p> <p>The <i>External</i> ground screw is provided for use only as a supplemental connection where required (or, permitted) by local codes or authorities.</p>
--	---

4.2 Probe Installation

NOTICE

Read the following information ***before*** installation.

The probe length is custom ordered to the tank requirements. Determine the probe length so that the probe tip is approximately at the 7 o'clock position of a cylindrical tank or 20 mm above the bottom of a vertical tank.

In cylindrical tanks, the probes are flexible and will wrap around the tank belly. Accommodate this circumference and the tank spool piece in the length calculation. A flanged connection is required on these installations.

In vertical tanks a rigid probe is provided and can be mounted from the top or from the side (at the bottom).

The PMC junction box should be mounted above the water surge level and in a protected area.

NOTICE

Install the probe with care. Teflon sheath is used to electrically isolate the metal probe from the liquid. Damage causing leaks may cause reading errors.

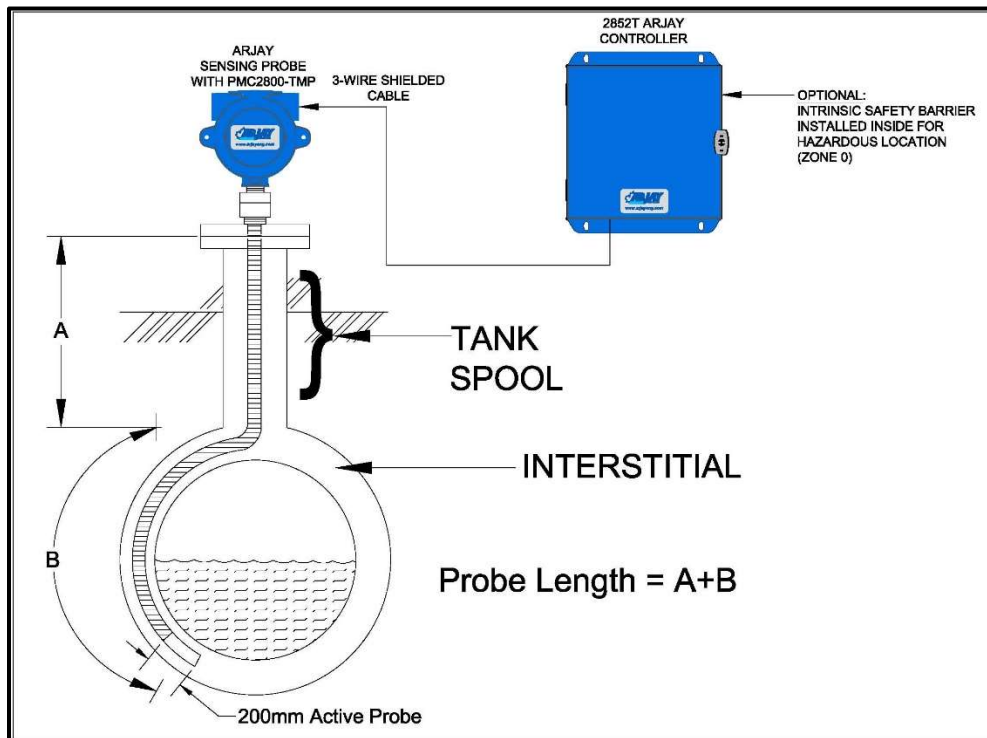

Figure 1 – Probe Installation (Flexible)

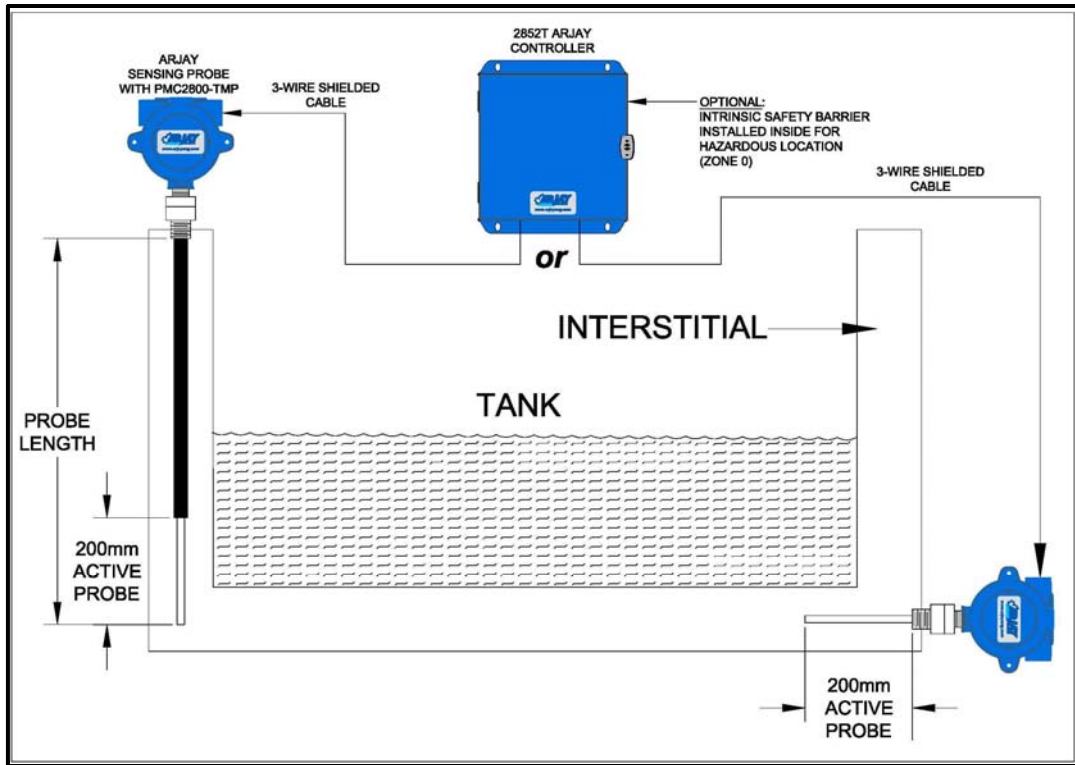

Figure 2 – Probe Installation (Rigid)

 CAUTION	INSTALL PROBE WITH CARE: IF TEFZEL ACTIVE PROBE IS DAMAGED, THE PROBE MAY NOT WORK.
--	--

5.0 CONTROLLER OVERVIEW

See specific drawing(s) attached to this manual for more detail

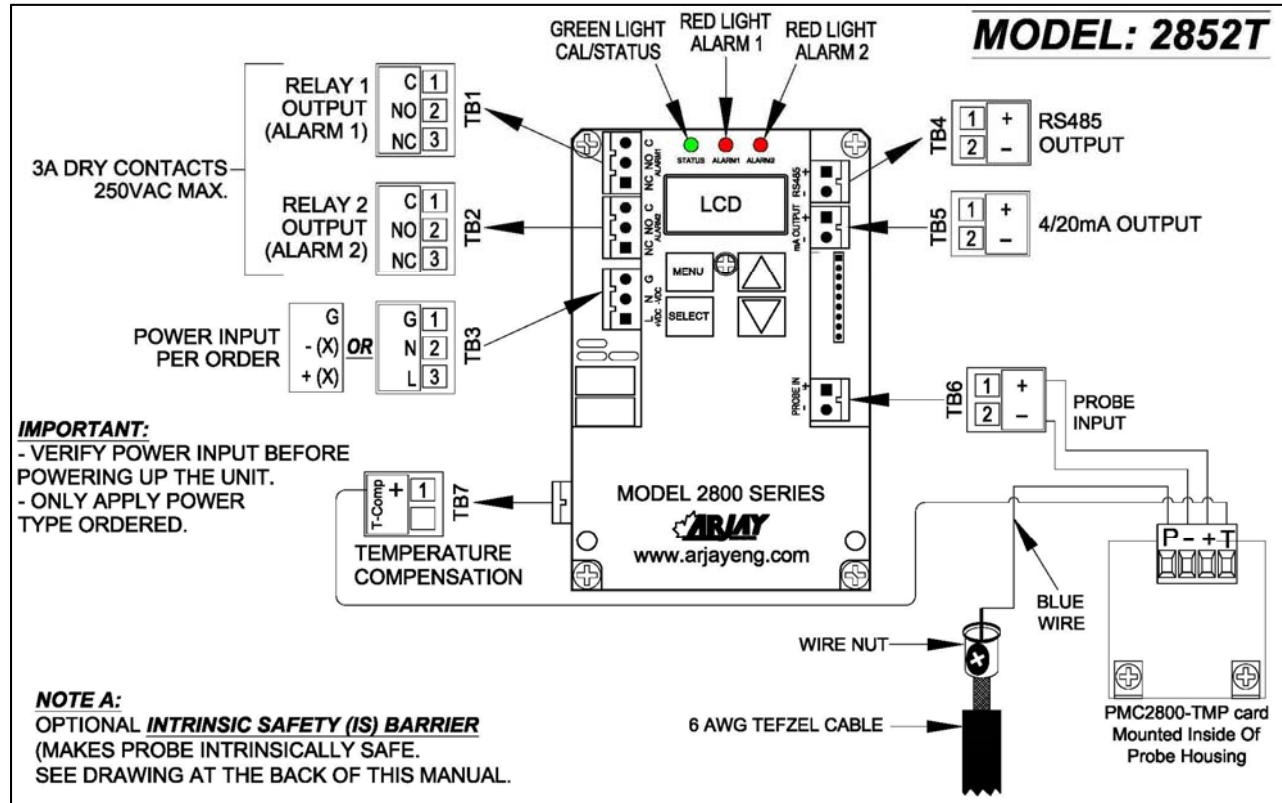

Figure 3 – CONTROLLER OVERVIEW

TB1/TB2 - Relay Output (Model 2852T only)

2 SPDT relay, Dry Contacts are 3A @ 250 VAC (Resistive), selectable failsafe or non-failsafe, selectable high or low acting alarm, programmable time delay: 0 – 600 seconds, 0-100% differential.

NOTICE

The controller relays are factory set in a Failsafe mode.

TB3 - Power Input

Power input as per Model. Check if ordered AC or DC. Earth ground is connected to Primary ground screw inside of enclosure.

TB4 - Network Output

Connect RS485 + and – to the network D+ and D-.

TB5 - mA Output

The 4/20mA is a sourced output referenced to Ground. It is not loop powered.
4mA = Normal 20mA = Alarm

TB6 - Probe Input

Probe is factory wired to “P” terminal of PMC2800T connector. The terminal block is disconnected during shipment for static reasons and has to be re-connected during installation. Connect ‘+’ to ‘+’ and ‘-’ to ‘-’ between the controller and the PMC card TB6. Check polarity to avoid damage.

TB7 – Temperature Compensation

Connect “T” wire to terminal block 7

5.1 Input / Output Terminal Specification

Input Terminals – Power Source					
Terminal ID	Overvoltage category	Rated Voltage (V)	Rated Current/power (A/W/VA)	— HZ or DC	Specified Mains fluctuation
TB3	II	100-240V	150mA	50/60Hz	± 10%
TB3	II	12 OR 24V	250mA	DC	+15% -10%

Input Terminals – Measuring Circuits					
Terminal ID	Function	Measurement Category	Nominal a.c. or d.c line to neutral voltage / if CAT I, Max. transient overvoltage Ut	Nominal a.c. or d.c current	Rating of insulation required for external circuit
TB6	Frequency	I	N/A	--	DI * or RI**
TB4	RS485 Communication	I	5V, 5mA / 0	--	DI * or RI**

* Double Insulation

**Reinforced Insulation

Output Terminals					
Terminal ID	Function	Isolation or protection	Rated V, A	Max. V, A	Load type and nominal
TB1	Load	Relay	3A Contact @250VAC	--	--
TB2	Load	Relay	3A Contact @250VAC	--	--
TB5	Current	Isolator(optional)	- 18V, 20mA, 900.Ω - 9V, 20mA, 450.Ω	50mA@18V	--
TB7	Voltage	None	24VDC, 30mA	--	Temperature Comp

5.2 Permanent Power Connection (AC Powered Models Only)

- 1) Connection to the building wiring system shall be in accordance with the Canadian Electrical Code (CEC), Part 1 in Canada, the National Electrical Code, ANSI/NFPA 70 in the USA, or the local electrical codes of the country where the equipment is being installed.
- 2) A disconnecting device is required. The disconnecting means shall disconnect all current-carrying conductors.
- 3) 15A circuit breaker or equivalent fuse is required.
- 4) An external switch or breaker shall be in close proximity to the equipment and within easy reach of the operator. The switch shall be marked as the disconnecting device for the equipment and include the symbols to its "ON" and "OFF" positions using the following symbols:



- 5) The wiring for AC power should be minimum 18 AWG / 300V or as required by local / country codes.
- 6) After field wiring, the primary wires must be secured to the enclosure by tie-wraps to maintain the separation from the signal wires.
- 7) Wiring diagram for permanent connection: See drawings at the back of this manual.
- 8) Use copper conductors only.

5.3 Glossary Of Symbols

	Attention, consult accompanying documents <i>Attention, veuillez consulter les documents ci-joints.</i>	
	Primary Protective Earth Ground <i>Primaire de terre de protection</i>	
	Secondary Earth Ground <i>Mise à la terre de secondaire</i>	
	Direct Current (DC) <i>Courant continu</i>	
	Normally closed relay contacts <i>Contacts Repos</i>	L
	Power on <i>Marche (mise sous tension)</i>	G
		N
		Live <i>Sous tension</i>
		Ground <i>Terre</i>
		Neutral <i>Neutre</i>

6.0 STARTUP AND CALIBRATION

6.1 Startup

Check that the power wiring, PMC wiring and probe are wired in accordance with the electrical installation drawing. Connect the probe terminal block TB6 as per figure 3.

Power On the unit. Allow a 1 hour warm-up period before calibrating.

The Status LED on the controller circuit board should be green. A red Status LED indicates a fault condition. If red, check the Troubleshooting section.

The LCD will scroll to the normal operating display. See section 10.0 Menu Flow Chart.

NOTICE

An instrument setup and field calibration is required on initial power up. See section 6.3 for controller setup and section 6.4 to calibrate the transmitter.

6.2 Menu Flow Chart Back Chart Background Information

The control setup, diagnostics, and calibration are accessed using the display and keypad on the controller. The Flow Chart in Section 10.0 provides an overview to the various menus and features. Keep a copy of the flow chart at hand when accessing the internal controller features.

Below is a description of the menu functions.

6.2.1 Menu Short Form

Since the 2852 controller has a small LCD, some menu description may be in short form. The following are the menu descriptions:

Short Form	Description
<i>Diags:</i>	<i>Diagnostics</i>
<i>Cal Pts:</i>	<i>Calibration points</i>
<i>Auto Cal:</i>	<i>Auto calibrate</i>
<i>Man Cal:</i>	<i>Manual calibrate</i>
<i>Cal Ok:</i>	<i>Calibrate ok</i>
<i>Cal Err:</i>	<i>Calibrate err</i>
<i>mA out:</i>	<i>mA output</i>
<i>mA Span:</i>	<i>mA output span</i>
<i>Sec:</i>	<i>Seconds</i>
<i>ALRM CAL:</i>	<i>Alarm Calibration</i>
<i>Cal:</i>	<i>Calibration point</i>

Short Form	Description
<i>SENS:</i>	<i>Sensitivity</i>
<i>A1:</i>	<i>Alarm relay 1</i>
<i>A2:</i>	<i>Alarm relay 2</i>
<i>Alrm:</i>	<i>Alarm</i>
<i>Alrm Lvl:</i>	<i>Alarm level</i>
<i>Diff A1</i>	<i>Differential of A1 alarm</i>
<i>Alrm Del:</i>	<i>Alarm Delay</i>
<i>^SP:</i>	<i>Relay Setpoint Hi action</i>
<i>vSP:</i>	<i>Relay Setpoint Low action</i>
<i>Net ID</i>	<i>Network Identification</i>

6.2.2 Menu Description

The 2852T-ILA controller will display Normal in its normal operating condition and **Alarm** during a wet ILA probe condition.

The 2852 controller has a password protect feature. The default password is 2000. See section 6.3.1 “Password” if wish to have a personal password.

From the main menu, you can select **Cal Only, View, and Change**.

Cal Only allows a one point calibration only. A password is required to enter this menu item and is described in the calibration section. Output parameters and other control features cannot be accessed through this menu. It is recommended to use this menu if only a re-calibration is to be done.

View allows an operator to view the **Calibration** setpoints in pF, the **Alarms** settings such as low or high action, failsafe or non-failsafe and the 0-600 second delay, the **Diagnostics** of raw readings and the **Setup** values such as mA output and ID address. This can be viewed without a password and without risk of changing any values. This information may be requested during technical assistance inquiries.

Change is password protected and allows an operator to change the configuration set-up values indicated in the View. The 2852T has a factory default parameters setup. The change menu is only required if there is a change to the initial setup of relay setpoints, delays, etc. or to re-set the values to the factory default.

6.2.3 Data Entry

Data Entry

Press <▲> / <▼> key to increase / decrease the digital value.

Press <SELECT> key to move the cursor.

Press <MENU> key to abort certain screens.

6.3 2852 Controller Setup

Power up the 2852 Controller. The status LED should be green. The LCD will scroll to the normal operating screen after a series of the following screens (each displays for 2 sec.). * It may read **Normal** or **Alarm** until a calibration is performed.

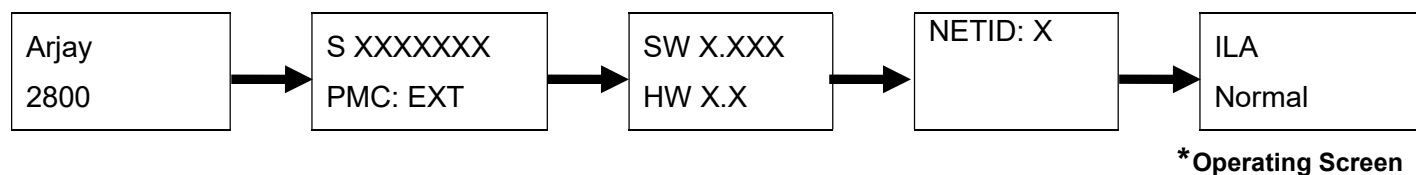

6.3.1 Setup And Network

The 2852T Controller has the following factory default setup parameters. These are factory set to the requirements of the application. If changes to the parameter is required then they can be accessed in the CHANGE menu. Follow through the flowchart in section 10.0 and input the settings as required.

Press and Hold the menu key to enter the main menu. Follow the Flow Chart procedure to access the **Change** menu. Toggle to access the **Setup** menu.

1. Sensitivity

The sensitivity determines the amount of picfard (pF) change required to cause an alarm. Since the dielectrics of liquids can vary greatly, the unit is shipped with a factory default of 3.0 pF (1.0pF for

short side wall entry). At this setting, the unit will alarm with about 50mm of water on the active probe or up to 100mm of oil on the active probe. A pF to mm relationship for your liquid cannot be factory determined due to dielectric and installation variables. If the Sensitivity value is changed in the field, it is recommended to consult technical factory support before proceeding. A leak test maybe advisable to confirm an alarm.

2. Diff A1

This is the differential of the relay set point. After the relays activate they will be held in this alarm state until the capacitance value (pF) decreased by this preset value. For ILA applications this feature is not used and therefore factory set for 0.0pF.

3. PMC (A,K & C Values)

These values are used to trim the accuracy of the electronics within the ILA sensor probe. They are recorded on the side of Pulse Card. They are factory set. Verify that the values are correct.

4. Defaults

Factory settings are pre-configured into the unit based on the most typical set-up required for this application. This provides for a quick and easy calibration at site but can be changed to suit specific applications. If the setup has been field changed, selecting this will change back to the factory defaults.

5. NET ID

The ID number is used only for network applications. To communicate on a network, each controller must have a unique ID number. The factory default ID number is 1.

NOTICE

If multiple units on a network have the same address, network errors will result.

6. Filter

Data filtering is used to smooth data from a sudden change and minimize fluctuating readings. For example, a 5 second setting means the calculated value of the capacitance and resulting values of pF will start to respond immediately but will take 5 seconds to reach their final values. The factory default is 0 to provide an immediate and active response. This can be user selected from 0 - 99.9 seconds.

7. Password

The unit is shipped with password "2000". The user can continue to use this password or may change to a personal password after installation. To change password go to "Change" menu and toggle down to "Setup" menu then to "Password". Press Select. Enter new password. The password "2000" is no longer available. Consult factory if new password has been forgotten.

6.3.2 Relay Setup Menu

Press and Hold the menu key to enter the main menu. Follow the Flow Chart procedure to access the **Change** menu. Toggle to access the **Alarm** menu.

The 2852T ILA Controller has 2 relays which operate together.

1. RELAY DELAY (Delay). Minimum time in seconds for an alarm to exist before the corresponding relay changes to its alarm state. The relay alarm state depends on the Relay Action and Failsafe settings. Factory default is 15 seconds. To suppress false alarms due to sudden of intermittent flows or disturbances in front of the sensor.
2. RELAY ACTION (Action). This determines if the Alarms LEDs should activate when the pF reading rises above or below the setpoint. The factory default is above the setpoint because the application of air to liquid is an increase in capacitance.

3. **FAILSAFE (Fsafe).** Failsafe typically means that the relay is normally (when not in an alarm condition) held in an energized state. In an alarm condition, the relay is de-energized i.e. identical to when the instrument power is shut off. The rationale is that the alarm condition should match the Power Fail condition. Factory default is Yes for failsafe.

6.4 2852 Controller Calibration

6.4.1 Site Calibration

A factory pre-configuration and set-up has been defaulted into the 2852-ILA. As such, a user set-up is not required in the field. A basic calibration is only required.

Before performing final calibration make sure probe is mounted in it's final position on the tank. Allow at least 1 hour warm-up before performing calibration.

As per the Flow Chart, press and hold Menu key for 5 seconds to enter the main menu. The display will read the first menu item **Cal only**. Press select key, enter password "2000". A pF reading of the sensor will be displayed. Press select to acknowledge and then press select to accept the new calibration. To abort, press the <MENU> key.

If the calibration is successful, the display will return to the main operating display and show normal condition. A simulation of the ILA alarm can be performed by placing fingers on the blue probe wire in the junction box. This will simulate an increase in capacitance. After the preset time delay, unit should go into alarm.

If there is any issue, call Arjay Engineering Ltd.: Toll free: (800) 387-9487 (North America Only), tel. +1 (905) 829-2418.

***THIS COMPLETES THE SETUP & CALIBRATION PROCEDURE FOR THE
2852T-ILA INTERSTITIAL TANK LEAK ALARM***

7.0 CONTROLLER NETWORK

The 2852 series Transmitter may be monitored and calibrated via RS-485 protocol compatible digital communications.

Typical features are:

1. Ease of wiring in multiple level point monitoring:

Up to 255 of Arjay 2852 Series transmitter or monitor may be connected together in a daisy chain (2 wire communication plus power wiring) connection to an Arjay Remote Access monitor or customer control system which allows viewing data and setup of any of the transmitters on the network. The 4-20mA output may still be used if necessary.

2. Setup for the 2852 for network operation:

Each 2852 controller must have a unique number to connect in a network system. See section 10.0 Menu Flow Chart, CHANGE menu for details to change the ID number.

7.1 MODBUS Configuration

Parameter settings: 9600 Baud Rate; Even Parity, 8 Data Bits and 1 Stop Bit.

Wiring connection: RS485 (+) connect to D+; RS485 (-) connect to D-.

See section 7.2 for Modbus Register mapping.

7.2 2800 Series MODBUS Register Mapping

REG	Zero Based	DESCRIPTION	TYPE	No. of Reg	Note
40001	0	Serial Number	float	2	
40003	2	Hardware Rev / Software Rev	byte	1	
40004	3	Spare / Mode	byte	1	
40005	4	Sensitivity A2 / Sensitivity A1	byte	1	Optional
40006	5	Instrument Status 1 / Instrument Status 0	byte	1	
40007	6	Model type / Modbus ID address	byte	1	
40008	7	Relay2 Setup / Relay 1 Setup	byte	1	
40009	8	Password	int	1	
40010	9	XA "A" cal parameter	float	2	
40012	11	XK "K" cal parameter	float	2	
40014	13	XC "C" cal parameter	float	2	
40016	15	Filter	float	2	
40018	17	Slope - pF per% level	float	2	Optional
40020	19	Offset - pF for empty vessel	float	2	Optional
40022	21	mA output span value	float	2	Optional
40024	23	mA output zero value	float	2	Optional
40026	25	mA output Trim Slope value	float	2	
40028	27	mA output Trim Offset value	float	2	
40030	29	Cal1 PV: Level calibration: 1st level point in %	float	2	Optional
40032	31	Cal2 PV: Level calibration: 2nd level point in %	float	2	Optional
40034	33	Cal1 pF: Level calibration: 1st capacitance value in pF	float	2	Optional
40036	35	Cal2 pF: Level calibration: 2nd capacitance value in pF	float	2	Optional
40038	37	Relay 1 : Differential High Alarm.	float	2	Optional
40040	39	Relay 2: Differential High Alarm.	float	2	Optional
40042	41	Relay 1: Differential Low Alarm.	float	2	
40044	43	Relay 2: Differential Low Alarm.	float	2	
40046	45	Relay 1 On delay [seconds]	int	1	
40047	46	Relay 2 On delay [seconds]	int	1	
40048	47	mA Analog Output	float	2	Optional
40050	49	Osc. Frequency	float	2	
40052	51	Frequency	float	2	
40054	53	Capacitance	float	2	
40056	55	Filtered Capacitance	float	2	
40058	57	Level	float	2	Optional
40060	59	Compensated pF for point level if enable Temperature compensation	float	2	Optional
40062	61	Temperature in mV	float	2	Optional
40064	63	Temperature in degree C	float	2	Optional
40066	65	Compensation factor: percent per degree	float	2	Optional
40068	67	Temperature at Calibration	float	2	Optional
40070	69	Temperature offset [mV at 0 dC]	float	2	Optional
40072	71	Temperature slope [mV per dC]	float	2	Optional
40074	73	Alarm 1 differential Off value	float	2	Optional
40076	75	Alarm 2 differential Off value	float	2	Optional

8.0 MAINTENANCE

There is no routine cleaning required for this controller.

9.0 TROUBLESHOOTING

CONDITION	DO THIS
1. Status LED is OFF and the LCD display is off	Check the power to the unit. If the unit is a 12VDC or 24VDC model, check the external source and polarity is correct. If the unit is a 100-240VAC model, then check the Line, Neutral and Ground wiring is correct.
2. If the status LED is RED	This indicates a major error such as memory failure, no probe signal etc. Check the following: <ul style="list-style-type: none"> • Make sure the PMC is installed & the PMC wiring is correct and there are no breaks in the wiring. At the controller, measure across the Probe Input terminals with a DC meter. Make sure “Common” lead of meter is on ‘-’ terminal. It should read (+) 8 to (+) 10 VDC with the PMC connected and approximately 20 to 24 VDC with the PMC terminal disconnected. • Microprocessor may have lost its parameters due to a power surge in the line. Go to Diagnostic in view Menu (see section 10.0 Flow Chart) to check the Calibration values, frequency and capacitance values then, call Arjay Technical Support.
3. No mA output OR incorrect mA output.	IMPORTANT: THE UNIT SOURCES mA OUT FROM THE mA OUTPUT TERMINAL. <u>THIS TERMINAL SHOULD NOT BE CONNECTED TO +24V.</u> IT IS NOT A 2 WIRE mA TRANSMITTER. See Figure 3 for Electrical hookup details. <ul style="list-style-type: none"> • Disconnect external wires from mA output and measure with mA Meter. • Check the mA output Action (direct or inverse) and mA output Span are set as desired. See section 10.0 Flow chart / Change menu. • If the mA output still does not match the alarm condition, then call Arjay Technical Support.
4. False Alarms	<ul style="list-style-type: none"> • Add some time delay in the unit • Make sure there is no external interference and electrical noise such as agitators, high voltage interference, turbulent flow, etc • Adjust the sensitivity to the next higher value. Test after any changes to confirm an alarm • Make sure the active probe end is in a dry condition
5. CAL Error No Change	<ul style="list-style-type: none"> • Make sure blue wire from probe end is connected to “P” terminal plug of PMC2800.
6. “NO SENSOR”	<ul style="list-style-type: none"> • Capacitance reading is less than 5pF. • Verify that the blue probe wire is connected to “P” terminal plug of PMC2800 Probe input.

ARJAY ENGINEERING TECHNICAL SUPPORT

(800) 387-9487

+1 (905) 829-2418

www.arjayeng.com

10.0 FLOW CHARTS

NORMAL OPERATING DISPLAY

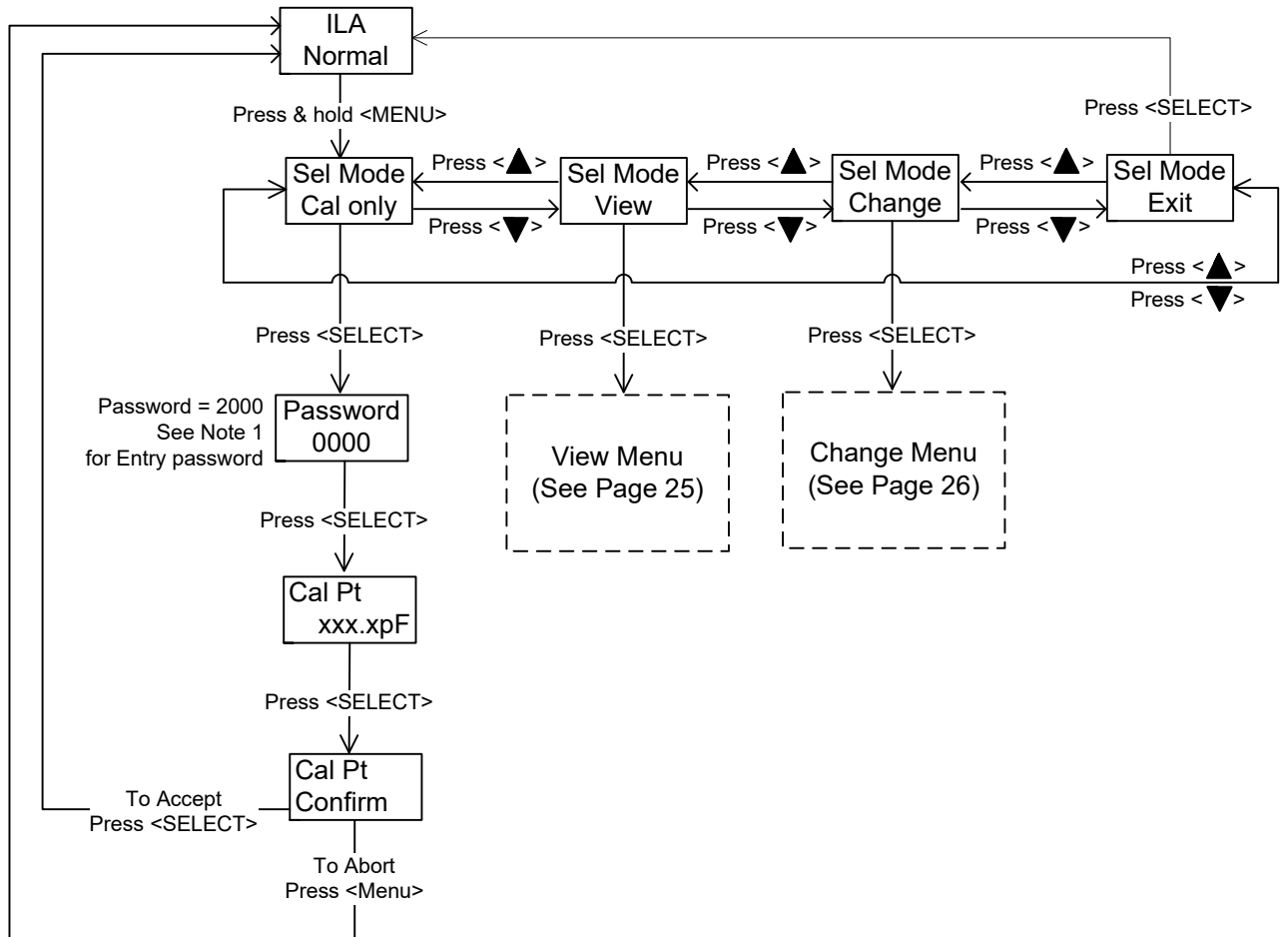

Note 1: Data Entry

Press <▲> / <▼> key to increase / decrease the digital value.

Press <SELECT> key to move the cursor.

VIEW MENU

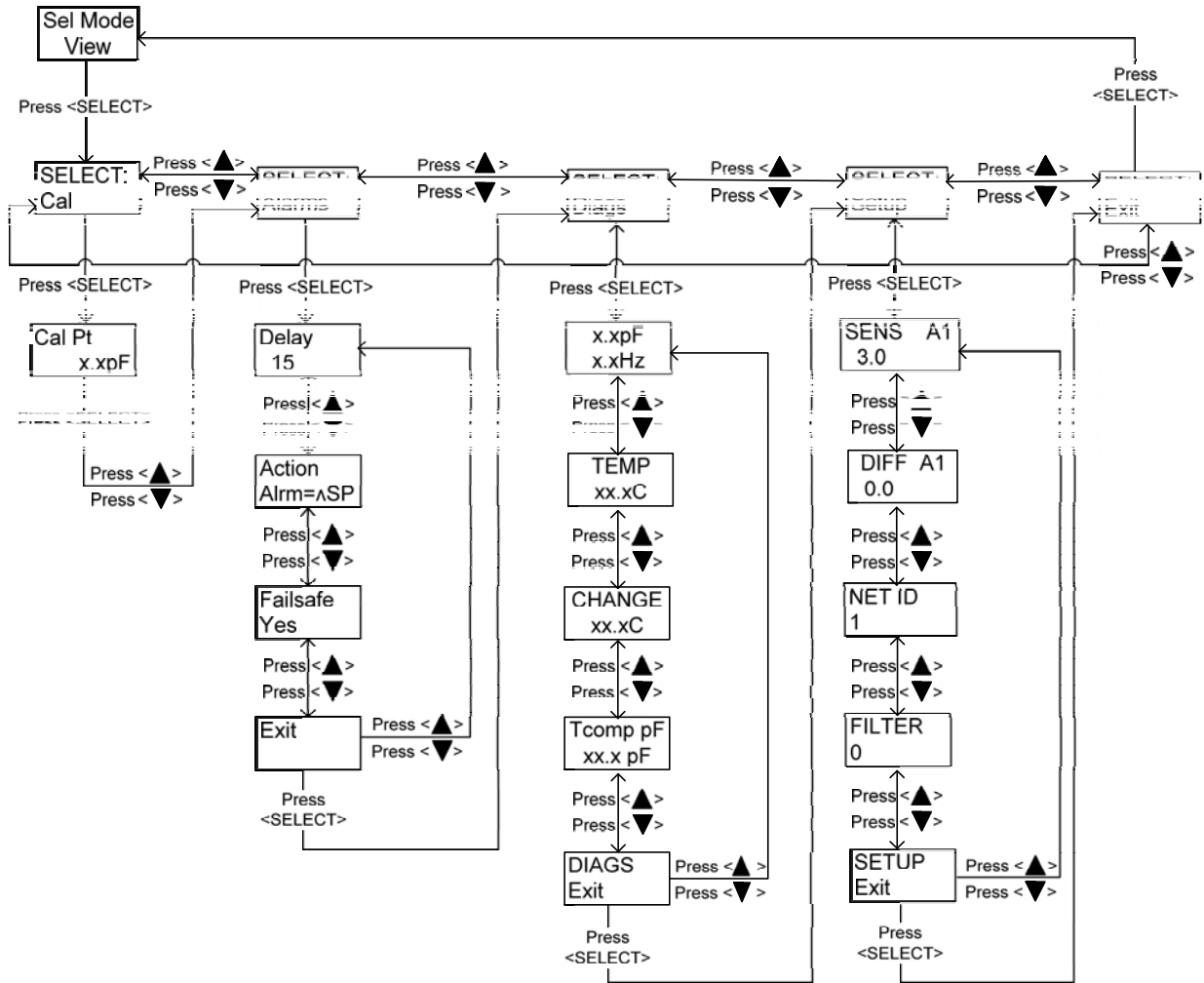

Note 1: Data Entry
 Press <▲> / <▼> key to increase / decrease the digital value.
 Press <SELECT> key to move the cursor.

CHANGE MENU

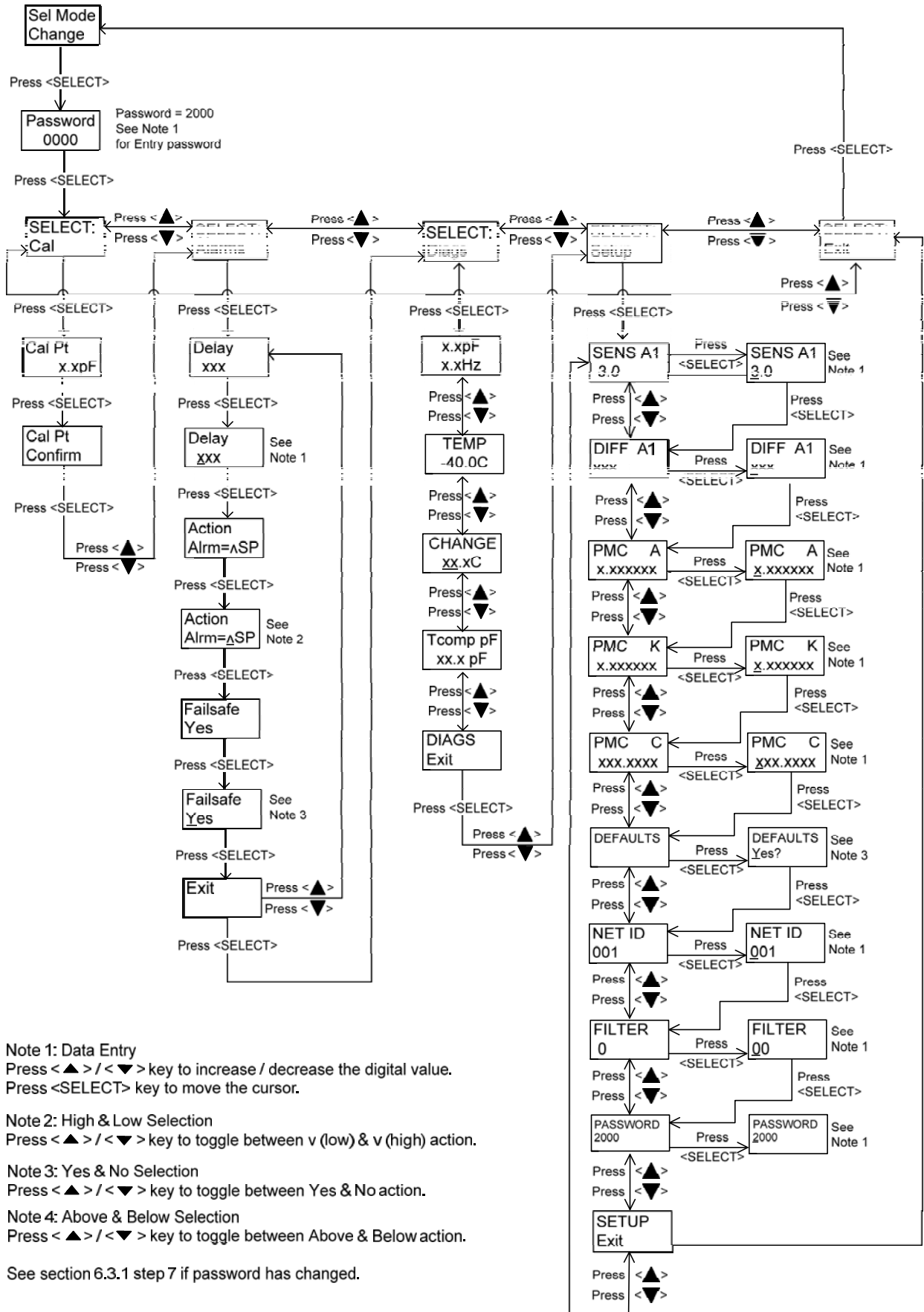

- Note 1: Data Entry
Press <▲> / <▼> key to increase / decrease the digital value.
Press <SELECT> key to move the cursor.
 - Note 2: High & Low Selection
Press <▲> / <▼> key to toggle between v (low) & v (high) action.
 - Note 3: Yes & No Selection
Press <▲> / <▼> key to toggle between Yes & No action.
 - Note 4: Above & Below Selection
Press <▲> / <▼> key to toggle between Above & Below action.
- See section 6.3.1 step 7 if password has changed.