



MODELS:

2852-HCF3

**FLOATING OIL SPILL ALARM WITH
DRY SUMP (AIR) MONITOR**



USER MANUAL (REV: 1.1)

ARJAY ENGINEERING LTD.		
2851 Brighton Road Oakville (Toronto), Canada L6H 6C9	TEL: ++1 (905) 829-2418 FAX: ++1 (905) 829-4701 NORTH AMERICA: 1-800-387-9487	WEBSITE: www.arjayeng.com EMAIL: arjay@arjayeng.com

THIS PAGE INTENTIONALLY LEFT BLANK

TABLE OF CONTENT

NOTICE

Please read the Installation Notes (4.0) prior to locating and mounting the instrument.

1.0	SPECIFICATION	4
2.0	USE HAZARD INFORMATION.....	6
3.0	INSTRUMENT OVERVIEW.....	7
3.1	Features	7
3.2	Model Number Table	7
4.0	INSTALLATION.....	8
4.1	Remote Mounted Controller Installation	8
4.2	Float Sensor Installation	9
5.0	CONTROLLER OVERVIEW.....	10
5.1	Input / Output Terminal Specification	11
5.2	Permanent Power Connection (AC Powered Models Only)	12
5.3	Glossary Of Symbols.....	12
6.0	STARTUP AND CALIBRATION.....	13
6.1	Startup	13
6.2	Menu Flow Chart Background Information	13
6.2.1	Menu Short Form.....	13
6.2.2	Menu Description.....	14
6.2.3	Data Entry.....	14
6.3	2852 Controller Setup.....	14
6.3.1	Setup And Network.....	14
6.3.2	Relay Setup Menu	16
6.4	2852 Controller Calibration	17
6.4.1	Site Calibration	17
7.0	CONTROLLER NETWORK.....	18
7.1	MODBUS Configuration	18
7.2	2800 Series MODBUS Register Mapping	19
8.0	MAINTENANCE.....	20
9.0	TROUBLESHOOTING.....	21
10.0	FLOW CHARTS.....	22

TABLE OF FIGURES

FIGURE 1 – 2852 SERIES CONTROLLER OVERVIEW.....	10
--	-----------



1.0 SPECIFICATION

Specifications are subject to change without notice

Specification	Details
Power Input: <i>(Specify voltage at time of Order)</i>	12VDC +15% /-10% or 24VDC +15% /-10%, 250mA maximum 100VAC – 240VAC +/- 10%, 50/60 Hz, 150mA maximum Note: DC input models must be supplied by Limited Energy power source. Limited Energy means compliance with one of the following requirements: <ul style="list-style-type: none"> - Class 2 circuit according to Canadian Electrical Code, Part, I, C22.1; - Class 2 circuit according to National Electrical Code, NFPA-70; - Limited Power Supply (LPS) according to IEC 60950-1; - Limited-energy circuit according to IEC 61010-1.
Connections to mains supply	Permanent (for AC/DC model)
User Interface: Display & Keypad Communication Interface:	Two line LCD display, Alarm status LEDs and Keypad for select menu or enter values Modbus (RS485)
Relays / Analog Outputs: Relay Outputs mA Signal Output (Set for A1)	2 SPDT relays, Dry Contacts are 3A @ 250 VAC (Resistive), selectable failsafe or non-failsafe, selectable high or low acting alarm, programmable time delay: 0 – 600 seconds , 0-100% differential 4mA during Normal and 20 mA during an alarm condition, 900 Ohms max (24VDC Power) OR 450 Ohms max (12VDC Power).
Instrument Performance: Measuring Range Setpoint Range Accuracy Resolution Calibration	0 - 5000 pF 2mm – 25mm surface oil 0.2% 0.05% of setpoint via network display 0.002% of Full Scale capacitance via network display Two Single point Auto calibration
Environmental: Operating conditions Operating Temperature Relative humidity Altitude Installation Category Pollution Degree Equipment mobility	Continuous -20 °C to +55 °C controller 0 to +55 °C Float Sensor with potted PMC 0 to 95% (non-condensing) ≤2000 m II 2 Fixed

Specification	Details
Mechanical Specification: Enclosure Rating Options on Enclosure	Refer to Dimensional Drawing Type 4 / IP65 Painted Steel (Blue) Type 4x / IP66 Polycarbonate (Gray) Type 4x / IP66 316 Stainless Steel Buzzer Pilot Light OR Strobe/Beacon Custom alarms
2800 Series Controller Certification (Ordinary Locations):	<ul style="list-style-type: none"> • UL file number: E343390 • UL / IEC 61010-1, 2nd Edition, 2008/10/28 (Electrical Equipment for Measurement, Control, and Laboratory Use; Part 1: General Requirements) • CAN/CSA-22.2 No. 61010-1, 2nd Edition, 2008/10/01, (Electrical Equipment for Measurement, Control, and Laboratory Use; Part 1: General Requirements) • CE: UL / IEC 61010-1; IEC / EN 61000-4; ISO 9001:2008
Sensor with Intrinsically safe option Certification (Hazardous Locations): Note: Must order Intrinsic Safety Barrier with controller Model 28XX-XXX-X-XXX1	<ul style="list-style-type: none"> • Class I, Division 1, Group A,B,C,D T4; • Class II, Division 1, Group E,F,G • Class III, Division 1: Ex ia IIC T4 Ga • Class I, Zone 0, Aex ia IIC T4 Ga • Ta: -40°C to +55°C

2.0 USE HAZARD INFORMATION

 CAUTION	Indicates a potentially hazardous situation that may result in minor or moderate injury.
 WARNING	Indicates a potentially or imminently hazardous situation which, if not avoided, could result in death or serious injury.
 DANGER	Indicates a potentially or imminently hazardous situation which, if not avoided, will result in death or serious injury.
NOTICE	Indicates a situation which, if not avoided, may cause damage to the instrument. Information that requires special emphasis.

3.0 INSTRUMENT OVERVIEW

The Model 2852-HCF3 Floating Oil Spill Alarm with Dry Sump (Air) Monitor provides a means for detecting hydrocarbon spills and separations on the water surface. The Arjay Tri-Float design contains a capacitance sensor that monitors the surface of the water. Water has a high dielectric constant, which results in a high capacitance reading. The dielectric of the oil is substantially lower than water, which results in a dramatic decrease in capacitance. When oil (or a similar hydrocarbon or low dielectric liquid) separates to the surface of the water, oil displaces the water surrounding the tri-float sensor.

The remote mounted Arjay 2852 controller monitors the capacitance change of the Tri-Float and activates a relay contact (A1) for use with alarms, pumps, valves, etc. The sensor requires at least 2 mm of surface oil to alarm.

A second relay (A2) is available to indicate a dry condition. The oil alarm will initially activate but will turn off once the dry condition is reached. The "AIR" alarm will only activate when the sump is dry.

NOTICE

During a dry situation the float sensor rests on the sump floor and the water drops below the sensor.

The complete 2852-HCF3 system consists of the float unit with potted PMC card, and the 2852 controller.

The standard float unit is constructed with a PVC sensor pod and three 316 stainless steel floats (A PVDF (kynar) sensor is available for high corrosive application). The support arms are 316 stainless steel. The floating sensor is supplied with 100ft of cable to the main 2852 controller. If longer cable is required then the customer will require a weather-proof splitter box and extra cable (e.g. Beldon 8772). The main 2852 controller and any splitter box used should be mounted safely above the water surge level. The PMC card which is potted within the float sensor translates the capacitance signal from the sensor into a frequency pulse, which can then be transmitted up to one kilometer to the 2852 controller via 3-wire shielded cable.

The standard model is intended for use in General Purpose non-hazardous areas. For hazardous location use refer to Arjay Engineering Ltd. for appropriate Intrinsically Safe model.

3.1 Features

- Microprocessor based RF capacitance level transmitter
- Two Differential Alarm relays (SPDT, 3A @ 250VAC)
- 4mA = Normal and 20mA = alarm output
- Modbus protocol via RS-485 for access by Arjay handheld, Central Access Panel or compatible system
- Local single point Auto calibration or remote calibration via network
- User specified custom features may be added by contacting Arjay Engineering Ltd.

3.2 Model Number Table

MODEL	DESCRIPTION
2852-HCF3-1	100-240VAC REMOTE MOUNTED 4/20mA (NON-ISOLATED) C/W 2 ALARM RELAYS
2852-HCF3-3	12VDC REMOTE MOUNTED 4/20mA (NON-ISOLATED) C/W 2 ALARM RELAYS
2852-HCF3-4	24VDC REMOTE MOUNTED 4/20mA (NON-ISOLATED) C/W 2 ALARM RELAYS

4.0 INSTALLATION

NOTICE	If any damage to the instrument is found, please notify an Arjay Engineering representative as soon as possible prior to installation.
NOTICE	Qualified Personnel must undertake all installations.

 WARNING	If the equipment is used in a manner not specified by the manufacturer, the protection provided by the equipment may be impaired.
--	--

4.1 Remote Mounted Controller Installation

Choose the mounting location in accordance with good instrument practice. Extremes of ambient temperature and vibration should be avoided (see specifications and installation drawing).

The 2852 controller may be mounted up to one kilometer from the float sensor using a minimum 20 gauge, 3-wire SHIELDED cable (Belden 8772 or Equivalent). 30 meter is supplied with the float sensor.

Check the polarity of the + and - wiring between the controller and the PMC prior to powering on the unit; + to Red and - to Black to avoid damage. Shield of cable and clear OR white wire should be connected to secondary ground terminal marked as \perp . Incoming Earth ground should be connected to primary ground terminal marked \oplus on sub plate.

NOTICE	The controller operates in a Failsafe Mode (factory default).
---------------	--

This means that the relays are in an energized state during normal operation. The N.O. relay contact will be held closed and the N.C. relay contact will be held open during a normal condition. This will allow the relay to return to its non-energized (shelf) state during an alarm, fault or power failure condition. Wire accordingly.

NOTICE	Maximum Conduit size for installation size is $\frac{3}{4}$" FNPT.
---------------	--

4.2 Float Sensor Installation

NOTICE

Read the following information **before** installation.

Connect the sensor cable to the 2852-HCF3 controller as per drawing attached to this manual OR download from the website.

Cut back the cable to length so that the float sensor can rest on the water surface at the lowest water level. As the water rises, the cable will hang into the water. The tri-float configuration is designed to support the cable and sensor. The maximum water travel distance is 2 meters.

The tri-float sensor is supplied with 30 meters of instrumentation cable between the float and the 2852-HCF3 controller. The sensor should be placed in an area of calm or protected water.

The 2852-HCF3 controller and any splitter box that is used should be mounted above the water surge level and in a protected area:

5.1 Input / Output Terminal Specification

Input Terminals – Power Source					
Terminal ID	Overvoltage category	Rated Voltage (V)	Rated Current/power (A/W/VA)	___ HZ or DC	Specified Mains fluctuation
TB3	II	100-240V	150mA	50/60Hz	± 10%
TB3	II	12 OR 24V	250mA	DC	+15% -10%

Input Terminals – Measuring Circuits					
Terminal ID	Function	Measurement Category	Nominal a.c. or d.c line to neutral voltage / if CAT I, Max. transient overvoltage Ut	Nominal a.c. or d.c current	Rating of insulation required for external circuit
TB6	Frequency	I	N/A	--	DI * or RI**
TB4	RS485 Communication	I	5V, 5mA / 0	--	DI * or RI**

* Double Insulation

**Reinforced Insulation

Output Terminals					
Terminal ID	Function	Isolation or protection	Rated V, A	Max. V, A	Load type and nominal
TB1	Load	Relay	3A Contact @250VAC	--	--
TB2	Load	Relay	3A Contact @250VAC	--	--
TB5	Current	Isolator(optional)	- 18V,20mA, 900Ω - 9V, 20mA, 450Ω	50mA@18V	--
TB7	Voltage	None	24VDC, 30mA	--	Buzzer / Pilot Light

5.2 Permanent Power Connection (AC Powered Models Only)

- 1) Connection to the building wiring system shall be in accordance with the Canadian Electrical Code (CEC), Part 1 in Canada, the National Electrical Code, ANSI/NFPA 70 in the USA, or the local electrical codes of the country where the equipment is being installed.
- 2) A disconnecting device is required. The disconnecting means shall disconnect all current-carrying conductors.
- 3) 15A circuit breaker or equivalent fuse is required.
- 4) An external switch or breaker shall be in close proximity to the equipment and within easy reach of the operator. The switch shall be marked as the disconnecting device for the equipment and include the symbols to its “ON” and “OFF” positions using the following symbols:



- 5) The wiring for AC power should be minimum 18 AWG / 300V or as required by local / country codes.
- 6) After field wiring, the primary wires must be secured to the enclosure by tie-wraps to maintain the separation from the signal wires.
- 7) Wiring diagram for permanent connection: See drawings at the back of this manual.
- 8) Use copper conductors only.

5.3 Glossary Of Symbols

	Attention, consult accompanying documents <i>Attention, veuillez consulter les documents ci-joints.</i>	
	Primary Protective Earth Ground <i>Primaire de terre de protection</i>	
	Secondary Earth Ground <i>Mise à la terre de secondaire</i>	
	Direct Current (DC) <i>Courant continu</i>	
	Normally closed relay contacts <i>Contacts Repos</i>	L
	Power on <i>Marche (mise sous tension)</i>	G
		N
		Live <i>Sous tension</i>
		Ground <i>Terre</i>
		Neutral <i>Neutre</i>

6.0 STARTUP AND CALIBRATION

6.1 Startup

Check that the power wiring and float sensor are wired in accordance with the electrical installation drawing. Connect the float sensor terminal block TB6 as per figure 1.

Power On the unit. Allow a 1 hour warm-up period before calibrating.

The Status LED on the controller circuit board should be green. A red Status LED indicates a fault condition. If red, check the Troubleshooting section.

The LCD will scroll to the normal operating display. See section 10.0 Menu Flow Chart.

NOTICE

An instrument setup and field calibration is required on initial power up. See section 6.3 for controller setup and section 6.4 to calibrate the transmitter.

6.2 Menu Flow Chart Background Information

The control setup, diagnostics, and calibration are accessed using the display and keypad on the controller. The Flow Chart in Section 10.0 provides an overview to the various menus and features. Keep a copy of the flow chart at hand when accessing the internal controller features.

Below is a description of the menu functions.

6.2.1 Menu Short Form

Since the 2852 controller has a small LCD, some menu description may be in short form. The following are the menu descriptions:

Short Form	Description
<i>Diags:</i>	<i>Diagnostics</i>
<i>Cal Pts:</i>	<i>Calibration points</i>
<i>Auto Cal:</i>	<i>Auto calibrate</i>
<i>Man Cal:</i>	<i>Manual calibrate</i>
<i>Cal Ok:</i>	<i>Calibrate ok</i>
<i>Cal Err:</i>	<i>Calibrate err</i>
<i>mA out:</i>	<i>mA output</i>
<i>mA Span:</i>	<i>mA output span</i>
<i>Sec:</i>	<i>Seconds</i>
<i>ALRM CAL:</i>	<i>Alarm Calibration</i>
<i>Cal:</i>	<i>Calibration point</i>

Short Form	Description
<i>SENS A1:</i>	<i>Sensitivity for A1</i>
<i>SENS A2:</i>	<i>Sensitivity for A2</i>
<i>Alrm:</i>	<i>Alarm</i>
<i>Alrm Lvl:</i>	<i>Alarm level</i>
<i>DIFF A1:</i>	<i>Differential A1 set value</i>
<i>DIFF A2:</i>	<i>Differential A2 set value</i>
<i>Del:</i>	<i>Alarm Delay</i>
<i>^SP:</i>	<i>Relay Setpoint Hi action</i>
<i>vSP:</i>	<i>Relay Setpoint Low action</i>
<i>Net ID</i>	<i>Network Identification</i>

6.2.2 Menu Description

The 2852-HCF3 controller will display **Normal** in its normal operating condition and **Oil Alarm** during an oil alarm and **Air Alarm** in a dry sensor condition.

The 2852 controller has a password protect feature. The default password is 2000. See section 6.3.1 “Password” if wish to have personal password.

From the main menu, you can select **Cal Only, View, and Change**.

Cal Only allows a one point calibration based on a factory or custom pre-configuration. In most applications, this is the only menu item required after the initial power-up. The calibration is required at site after power up or anytime a component or sensor is changed out. A password is required to enter this and is described in the calibration section.

View allows an operator to view the **Calibration** setpoints in pF, the **Alarms** settings (2852 only) such as low or high action, failsafe or non-failsafe and the 0-600 second delay, the **Diagnostics** of raw readings and the **Setup** values such as sensitivity & differential of each alarm point and ID address and filter. This can be viewed without a password and without risk of changing any values. This information may be requested during technical assistance inquiries.

Change is password protected and allows an operator to change the configuration set-up values indicated in the View. Changes will be required for the initial setup of relay setpoints, delays, span etc. or to re-set the values to the factory default.

6.2.3 Data Entry

Data Entry

Press <▲> / <▼> key to increase / decrease the digital value.

Press <SELECT> key to move the cursor.

Press <MENU> key to abort certain screens.

6.3 2852 Controller Setup

Power up the 2852 Controller. The status LED should be green. The LCD will scroll to the normal operating screen after a series of the following screens (each displays for 2 sec.). * It may read **Normal, Oil Arm** or **Air Alarm** until a calibration is performed.

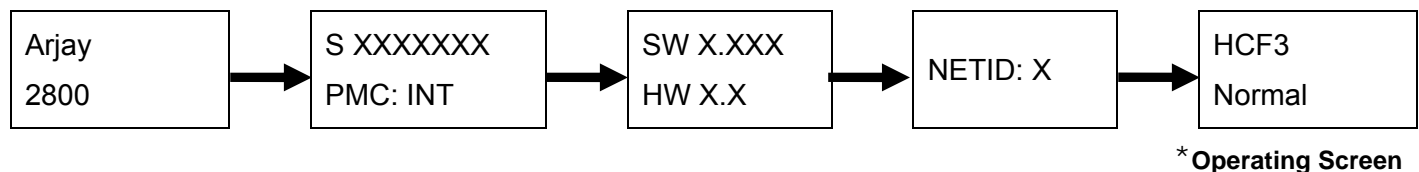

The PMC card which is potted in the floating sensor has three personalized values that must be entered into the controller. These are factory entered at time of shipment but should be verified prior to calibration or any time a HCF sensor is changed out. Go to change menu.

6.3.1 Setup And Network

Press and Hold the menu key to enter the main menu. Follow the Flow Chart procedure to access the **Change** menu. Toggle to access the Setup menu.

The 2852 Controller has the following setup parameters. These must be set up to the requirements of the application and can be accessed in the CHANGE menu. Follow through the flowchart in section 10.0 and input the settings as required.

1. Sensitivity (A1)

The sensitivity A1 determines the amount of pF change required to cause an OIL alarm. The factory default setting is 1.0 pF. This value causes an alarm with about 2 mm of surface oil (it is not recommended to go less than 1pF as a nuisance alarm may occur due to turbulence of water and temperature. Increasing the pF value will increase the amount of surface oil required to cause an alarm. Maximum sensitivity is 12.5pF at 25mm. Since different oils and the conditions of the oil/water separation can affect the pF change, a direct pF to mm relationship cannot be factory determined. If this is changed in the field, it should be tested to confirm an alarm.

2. Sensitivity (A2)

The sensitivity A2 determines the amount of pF change required to de-sensitize the AIR alarm. Since the AIR alarm is calibrated in a dry state, there may be some moisture left on the sensor after a "DRY" condition occurs. The factory setting is 1.0 pF.

3. Differential

The differential setting is used to keep the relay energized for a preset value in pF. This feature would be used for pump control in which the pump will come on when the oil level is reached and stay on until the oil level is reduced to a clean water value. For HCF3 applications, this value is factory set at 0.0 since most application do not require automatic pump control.

4. AKC Values

These values are used to trim the accuracy of the electronic within the HCF sensor. They are recorded on the side of the HCF sensor. They are factory set. Verify that the values are correct.

5. Defaults

Factory settings are pre-configured into the unit based on the most typical set-up required for this application. This provides for a quick and easy calibration at site but can be changed to suit specific applications. If the setup has been field changed, selecting this will change back to the factory defaults.

6. NET ID

The ID number is used only for network applications. To communicate on a network, each controller must have a unique ID number. The factory default ID number is 1.

NOTICE

If multiple units on a network have the same address, network errors will result.

7. Filter

Data filtering is used to smooth data from a sudden change and minimize fluctuating readings. For example, a 5 second setting means the calculated value of the capacitance and resulting values of pF will start to respond immediately but will take 5 seconds to reach their final values. The factory default is 0 to provide an immediate and active response. This can be user selected from 0 - 99.9 seconds.

8. Password

The unit is shipped with password "2000". The user can continue to use this password or may change to a personal password after installation. To change password go to "Change" menu and toggle down to "Setup" menu then to "Password". Press Select. Enter new password. The password "2000" is no longer available. Consult factory if new password has been forgotten.

6.3.2 Relay Setup Menu

Press and Hold the menu key to enter the main menu. Follow the Flow Chart procedure to access the **Change** menu. Toggle to access the Setup menu.

The two relays on the 2852-HCF3 are for Oil Detection (A1) and Air Detection (A2). Following parameters are available as a common setting for the two relays:

1. RELAY DELAY. Minimum time in seconds for an alarm to exist before the relays change to an alarm state. The relay alarm state depends on the Relay Action and Failsafe settings. The factory setting is 10 seconds. to suppress false alarms due to sudden or intermittent flows or disturbances in front of the sensor.
2. ALARM CALIBRATION ABOVE OR BELOW SETPOINT. This setting advises the controller if the calibrated pF value is above or below the alarm setpoint. For the HCF3, the calibration pF value is above the setpoint because the unit is required to alarm at a lower pF value, which indicates oil. The factory default is Above Setpoint.
3. RELAY ACTION. This determines if the Alarms LEDs should activate when the pF reading rises above or below the setpoint. The factory default is below the setpoint because the application of water to oil is a decrease in capacitance.
4. FAILSAFE. Failsafe typically means that the relay is held in an energized state when in a normal operating condition as opposed to an alarm condition. In an alarm condition, the relay de-energizes which is identical to when the instrument power is shut off. The rationale is that the alarm condition should match the Power Fail condition. The factory default is Yes for Failsafe.

6.4 2852 Controller Calibration

6.4.1 Site Calibration

A factory pre-configuration and set-up has been defaulted into the 2852-HCF3. As such, a user set-up is not required in the field. A basic calibration is only required.

Allow one hour warmup before proceeding to calibration.

As per the Flow Chart, press and hold Menu key for 5 seconds to enter the main menu. The display will read the first menu item **Cal only**. Press select key and Enter password (see section 6.3.1 “Password”). A pF reading of the sensor will be displayed. Press select to acknowledge and then press select to accept the new calibration. To abort, press the MENU key.

CAL A1:

This alarm point is used to calibrate the sensor on water (offset) for oil detection. Press select, display will read A1 and present pF value. With the sensor floating on clean water Press select and then Press select again to “confirm”.

CAL A2:

This alarm point is used to calibrate the dry condition on sensor. Press select, display will read A2 and present pF value. Remove sensor from the water and wipe dry. pF value will decrease from the previous water condition. Press select and Press select again to “confirm”. Display should return to main operating display and should read “Air Alarm” when out of water.

Place sensor back in water and display should read “Normal”.

If the calibration is successful, the display will return to the main operating display and show normal condition.

***THIS COMPLETES THE SETUP & CALIBRATION PROCEDURE FOR THE
2852-HCF3 SERIES FLOATING OIL SPILL ALARM***

7.0 CONTROLLER NETWORK

The *28XX series Transmitter may be monitored and calibrated via RS-485 protocol compatible digital communications.

Typical features are:

1. Ease of wiring in multiple level point monitoring:

Up to 255 of Arjay *28XX Series transmitter or monitor may be connected together in a daisy chain (2 wire communication plus power wiring) connection to an Arjay Remote Access monitor or customer control system which allows viewing data and setup of any of the transmitters on the network. The 4-20mA output may still be used if necessary.

2. Setup for the *28XX for network operation:

Each *28XX controller must have a unique number to connect in a network system. See section 10.0 Menu Flow Chart, CHANGE menu for details to change the ID number.

***Where "XX" = 51 or 52**

7.1 MODBUS Configuration

Parameter settings: 9600 Baud Rate; Even Parity, 8 Data Bits and 1 Stop Bit.

Wiring connection: RS485 (+) connect to D+; RS485 (-) connect to D-.

7.2 2800 Series MODBUS Register Mapping

REG	Zero Based	DESCRIPTION	TYPE	No. of Reg	Note
40001	0	Serial Number	float	2	
40003	2	Hardware Rev / Software Rev	byte	1	
40004	3	Spare / Mode	byte	1	
40005	4	Sensitivity A2 / Sensitivity A1	byte	1	Optional
40006	5	Instrument Status 1 / Instrument Status 0	byte	1	
40007	6	Model type / Modbus ID address	byte	1	
40008	7	Relay2 Setup / Relay 1 Setup	byte	1	
40009	8	Password	int	1	
40010	9	XA "A" cal parameter	float	2	
40012	11	XK "K" cal parameter	float	2	
40014	13	XC "C" cal parameter	float	2	
40016	15	Filter	float	2	
40018	17	Slope - pF per% level	float	2	Optional
40020	19	Offset - pF for empty vessel	float	2	Optional
40022	21	mA output span value	float	2	Optional
40024	23	mA output zero value	float	2	Optional
40026	25	mA output Trim Slope value	float	2	
40028	27	mA output Trim Offset value	float	2	
40030	29	Cal1 PV: Level calibration: 1st level point in %	float	2	Optional
40032	31	Cal2 PV: Level calibration: 2nd level point in %	float	2	Optional
40034	33	Cal1 pF: Level calibration: 1st capacitance value in pF	float	2	Optional
40036	35	Cal2 pF: Level calibration: 2nd capacitance value in pF	float	2	Optional
40038	37	Relay 1 : Differential High Alarm.	float	2	Optional
40040	39	Relay 2: Differential High Alarm.	float	2	Optional
40042	41	Relay 1: Differential Low Alarm.	float	2	
40044	43	Relay 2: Differential Low Alarm.	float	2	
40046	45	Relay 1 On delay [seconds]	int	1	
40047	46	Relay 2 On delay [seconds]	int	1	
40048	47	mA Analog Output	float	2	Optional
40050	49	Osc. Frequency	float	2	
40052	51	Frequency	float	2	
40054	53	Capacitance	float	2	
40056	55	Filtered Capacitance	float	2	
40058	57	Level	float	2	Optional
40060	59	Compensated pF for point level if enable Temperature compensation	float	2	Optional
40062	61	Temperature in mV	float	2	Optional
40064	63	Temperature in degree C	float	2	Optional
40066	65	Compensation factor: percent per degree	float	2	Optional
40068	67	Temperature at Calibration	float	2	Optional
40070	69	Temperature offset [mV at 0 dC]	float	2	Optional
40072	71	Temperature slope [mV per dC]	float	2	Optional
40074	73	Alarm 1 differential Off value	float	2	Optional
40076	75	Alarm 2 differential Off value	float	2	Optional

*Option may or may not apply depends on the model type ordered.

8.0 MAINTENANCE

There is no routine cleaning required for this controller.

9.0 TROUBLESHOOTING

CONDITION	DO THIS
1. Status LED is OFF and the LCD display is off	Check the power to the unit. If the unit is a 12VDC or 24VDC model, check the external source and polarity is correct. If the unit is a 100-240VAC model, then check the Line, Neutral and Ground wiring is correct.
2. If Status indicator is RED (Fault Condition) OR "No XMTR"	<ul style="list-style-type: none"> • This indicates that the controller is not receiving a signal from the sensor. • Verify that the polarity of sensor wires is correct as per electrical drawing. Clear wire to "+", Black wire to "-". Measure 8-10 Volts DC across +/- terminals. • Make sure there is no break in the wiring between controller and sensor. • If using a splitter box ensure that proper connections have been made. • Replace the sensor with a spare if available.
3. No mA output OR incorrect mA output.	<p>IMPORTANT: THE UNIT SOURCES mA OUT FROM THE mA OUTPUT TERMINAL. <u>THIS TERMINAL SHOULD NOT BE CONNECTED TO +24V.</u> IT IS NOT A 2 WIRE mA TRANSMITTER. See Figure 1 for Controller Overview.</p> <ul style="list-style-type: none"> • Disconnect external wires from mA output and measure with mA Meter. • Check the mA output Action (direct or inverse) and mA output Span are set as desired. See section 10.0 Flow chart / Change menu. • If the mA output still does not match the level, then call Arjay Technical Support.
4. False Alarms	<ul style="list-style-type: none"> • Add some time delay to unit. • Add more sensitivity to unit. Note: More sensitivity will require more oil to detect. • Make sure there is no outside interference that may be causing false alarms such as an agitator, high voltage line parallel with sensor cable, turbulent water or floating sensor is obstructed from floating on water.

ARJAY ENGINEERING TECHNICAL SUPPORT

(800) 387-9487

+1 (905) 829-2418

www.arjayeng.com

10.0 FLOW CHARTS

NORMAL OPERATING DISPLAY

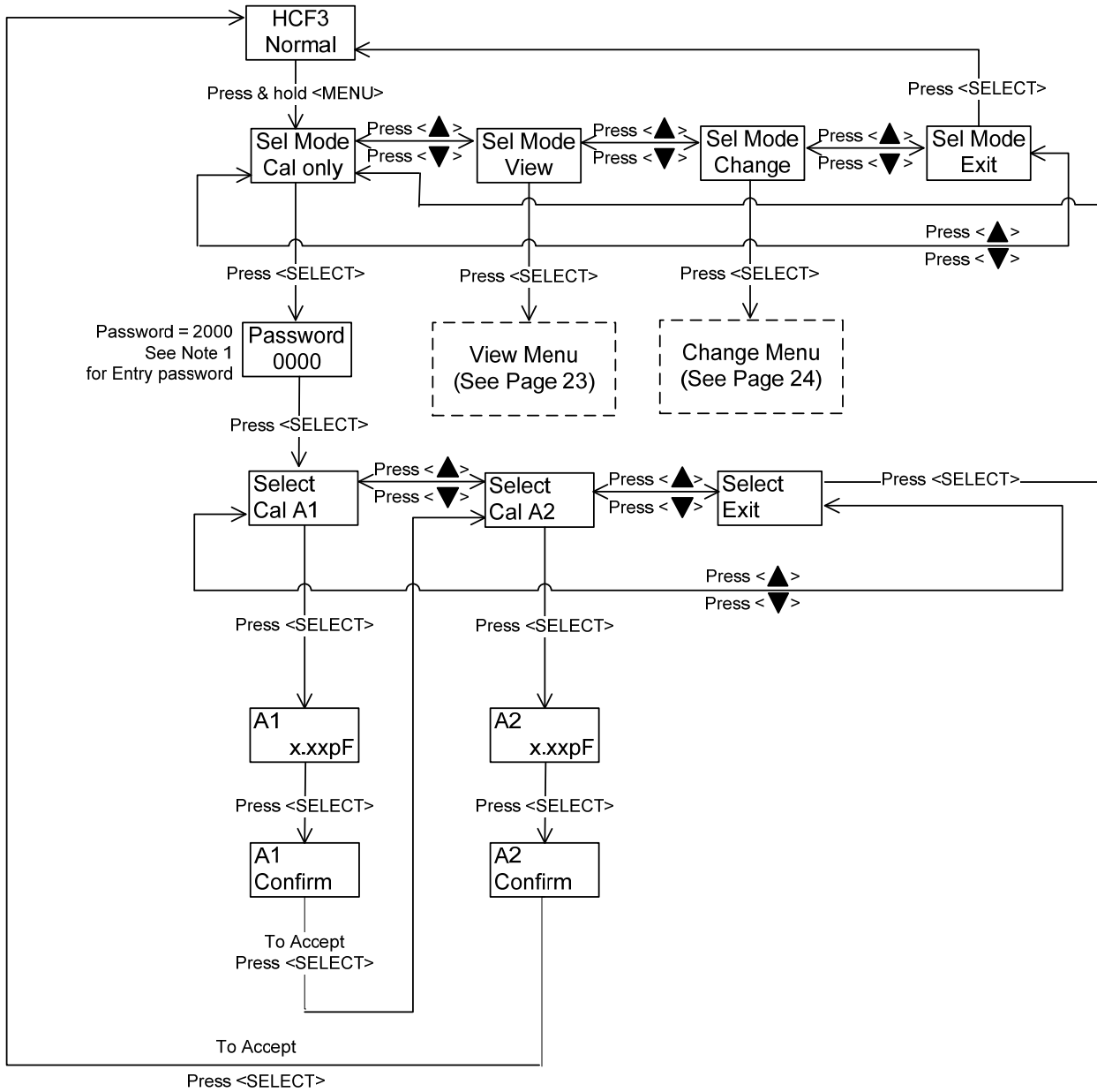

Note 1: Data Entry
 Press <▲> / <▼> key to increase / decrease the digital value.
 Press <SELECT> key to move the cursor.
 See section 6.3.1 step 7 if password has changed.

VIEW MENU

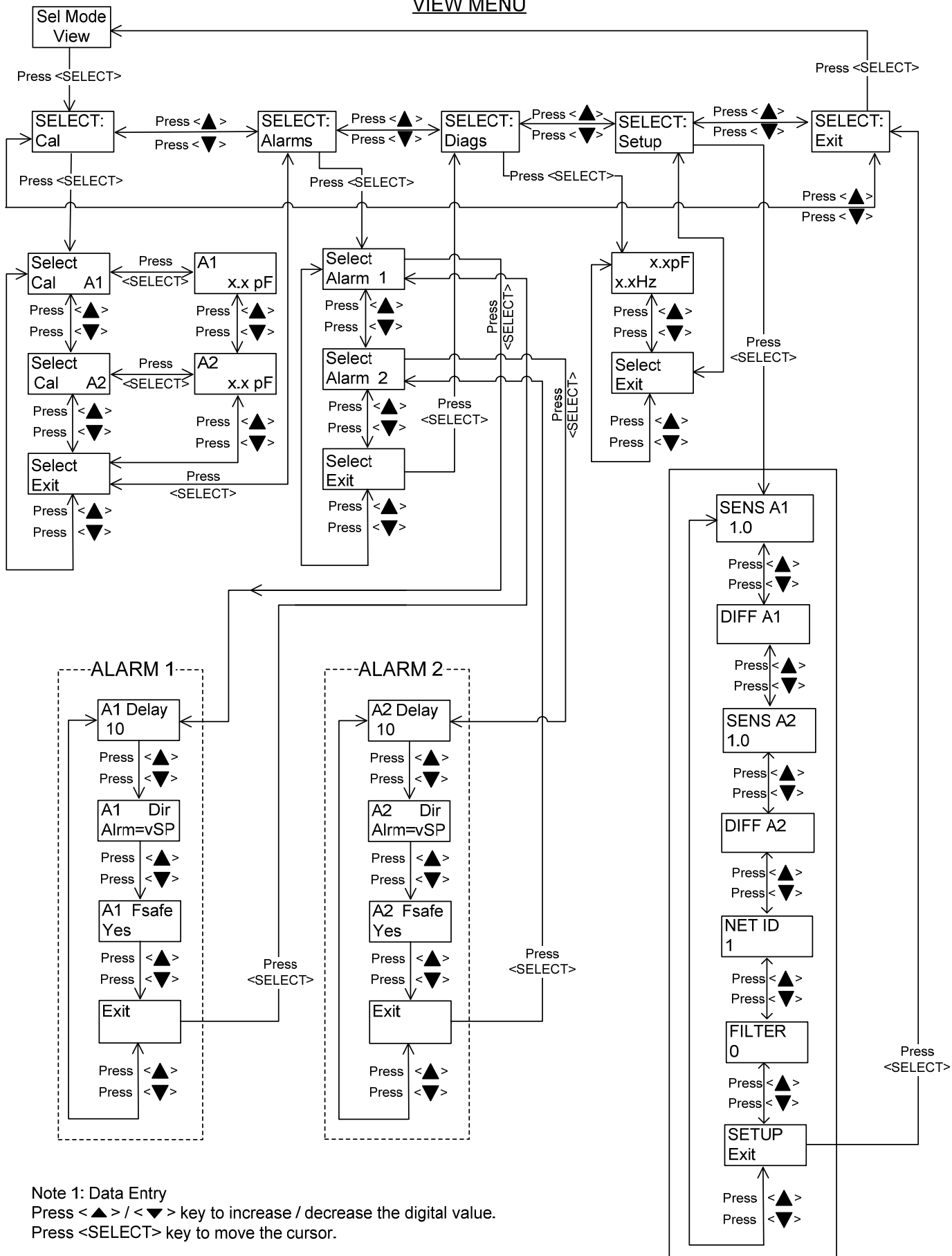

Note 1: Data Entry
 Press <▲> / <▼> key to increase / decrease the digital value.
 Press <SELECT> key to move the cursor.

CHANGE MENU

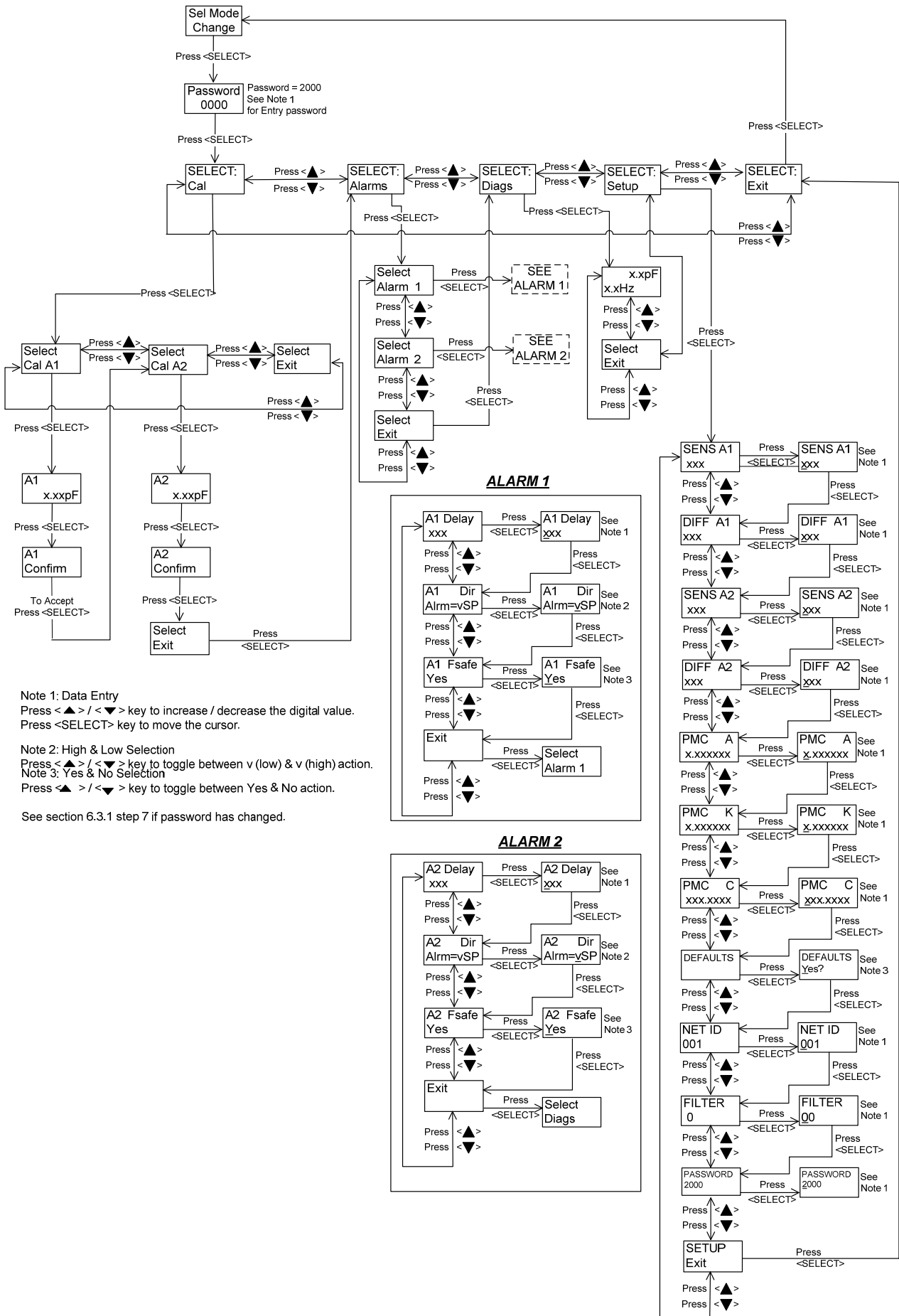

Note 1: Data Entry

Press <▲> / <▼> key to increase / decrease the digital value.
 Press <SELECT> key to move the cursor.

Note 2: High & Low Selection

Press <▲> / <▼> key to toggle between v (low) & v (high) action.

Note 3: Yes & No Selection

Press <▲> / <▼> key to toggle between Yes & No action.

See section 6.3.1 step 7 if password has changed.