



MODEL 2852-FCS Foam Control Switch

User Manual

Technical Support
Continental North America Toll Free 1-(800) 387-9487
Ph: +1 (905) 829-2418 Fx: +1 (905) 829-4701



A Product of Arjay Engineering Ltd.
Oakville, Ontario, Canada

www.ArjayEng.com

<i>MODEL:</i>	
<i>HARDWARE NO.:</i>	
<i>SOFTWARE NO.:</i>	
<i>SERIAL NO.:</i>	

TABLE OF CONTENTS

1.0	INSTRUMENT OVERVIEW	3
1.1	Features	3
1.2	Model Number vs. Voltage Input	3
1.3	Specifications	4
2.0	INSTALLATION.....	6
2.1	Controller Installation.....	6
2.1.1	Permanent Power Connection (AC Powered Models only).....	6
2.2	Probe Installation.....	7
2.3	Electrical Installation.....	9
2.3.1	Input / Output Terminal Specification	10
2.4	Glossary of Symbols	11
3.0	STARTUP AND CALIBRATION	12
3.1	Startup	12
3.2	Menu Flow Chart Background Information	12
3.2.1	Menu Description	12
3.2.2	Menu Description	12
3.2.3	Data Entry	13
3.3	2852 Controller Calibration.....	13
	13	
3.3.1	Site Calibration	13
4.0	SETUP and ALARM.....	15
4.1	2852 Controller Setup	15
4.2	2852 Controller Alarms.....	15
4.3	2852 Controller Network.....	17
4.3.1	Modbus Configuration	17
4.3.2	2800 Series Modbus Register Mapping	18
5.0	MAINTENANCE	19
6.0	TROUBLESHOOTING	20
7.0	FLOW CHARTS	21

TABLE OF FIGURES

Figure 1 – Probe Installation	8
Figure 2 – Typical Application.....	8
Figure 3 – Electrical Installation Overview	9
Figure 4 – No Differential Application – High Level	16
Figure 5 – No Differential Application – Low Level	16

1.0 INSTRUMENT OVERVIEW

The Arjay Model 2852-FCS Foam Control Switch provides two independent alarm relays for monitoring and control of foam in tanks, sumps and vessels.

The Arjay system has an active capacitance probe that is inserted into the vessel. As the foam level approaches or changes around the probe, the capacitance reading of the probe increases or decreases. The controller relays are calibrated to alarm at user determined levels of product on the probe.

The remote mounted Arjay 2852 controller monitors the capacitance change of the probe and activates the relay contacts for use with alarms, pumps, valves, etc.

The complete 2852-FCS system consists of the probe, the PMC card, and the 2852 controller.

The standard probe is constructed of a Teflon coated SS rod. The PMC card is mounted in a junction box mounted on top of the probe. The PMC card translates the capacitance signal from the probe into a frequency pulse, which is then transmitted up to one kilometer to the 2852 controller via 2-wire shielded cable.

Probes can be inserted vertically, horizontally, or angled into the tank. The sensor does not differentiate between liquid and foam. This system is designed to alarm for foam presence in a normal air condition.

On vertical and angled probes, the two relays can be set at the same or different levels. Each relay also has a differential setpoint to allow the relay to activate at one level and de-activate at a different level. This is similar to a latching format which can cycle a valve or control action between two points through the use of only one relay. For example, the defoamer spray can be activated at a high point and held on until the foam reaches a desired lower point.

On a horizontal insertion, both relays are calibrated to the same setpoint.

For single point high foam level applications, it is typical for both relays to be calibrated without bringing the foam level up to a specific alarm point. For example, in a high alarm application, the controller can be calibrated to air. An alarm will occur when the foam approaches and begins to cover the probe.

This model is intended for use in General Purpose non-hazardous areas. For hazardous location use refer to Arjay Engineering Ltd. for the appropriate model.

1.1 Features

- Microprocessor based capacitance Controller
- Relay and 4/20mA alarm output
- Modbus protocol via RS-485 for access by Arjay handheld, Central Access Panel or compatible system
- Local Auto calibration or remote calibration via network
- User specified custom features may be added by contacting Arjay Engineering Ltd.

1.2 Model Number vs. Voltage Input

- 2852-FCS-1 100-240 VAC power input
- 2852-FCS-3 12 VDC power input
- 2852-FCS-4 24 VDC power input

1.3 Specifications

Power Input:	12 VDC +15% /-10% or 24 VDC +15% /-10%, 250mA maximum 100VAC – 240VAC +/- 10%, 50/60 Hz, 150mA maximum Note: DC input models must be supplied by Limited Energy power source. Limited Energy means compliance with one of the following requirements: <ul style="list-style-type: none"> - Class 2 circuit according to Canadian Electrical Code, Part, I, C22.1; - Class 2 circuit according to National Electrical Code, NFPA-70; - Limited Power Supply (LPS) according to IEC 60950-1; - Limited-energy circuit according to IEC 61010-1.
Connections to mains supply	Permanent (for AC/DC model)
User Interface:	
Display & Keypad	Two line LCD with Alarm status display, select menu or enter values by keypad (display is internal to housing and used for set-up and diagnostics only)
Communication Interface:	Modbus (RS485)
Analog /Relay Outputs:	
mA Signal Output	4 mA during Normal and 20 mA during an alarm condition, 900 Ohms max OR 450 Ohms max (12VDC Power) *Set for Relay 1 only
Relay Output	2 SPDT relay, dry, N.O. Contact 5A @ 250 VAC (Resistive) and N.C. Contact 3A @ 250VAC (Resistive), selectable failsafe or non-failsafe, selectable high or low acting alarm, programmable time delay: 0 – 600 seconds
Instrument Performance:	
Measuring Range	0 - 5000 pF (most applications are 100pF to 1000pF)
Accuracy	0.2% of setpoint
Resolution	0.05% of setpoint via network display 0.002% of Full Scale capacitance via network display
Calibration	Single point per relay: Auto calibration
Environmental:	
Operating conditions	Continuous
Operating Temperature	-20 °C to +55 °C controller -60 °C to +55 °C PMC -60 °C to + 260 °C probe
Relative humidity	0 to 95% (non-condensing)
Altitude	≤2000 m
Installation Category	II
Pollution Degree	2

Equipment mobility	Fixed
Mechanical Specification:	Refer to Dimensional Drawing
Enclosure Rating	Type 4 / IP65 Painted Steel (Blue) Type 4x / IP66 Polycarbonate (Gray) Type 4x / IP66 316 Stainless Steel
Options on Enclosure	Buzzer (Tagged to Alarm 2 setting) Pilot Light OR Strobe/Beacon (Tagged to Alarm 2 setting) Custom alarms
Approval Standards:	<ul style="list-style-type: none"> • UL / IEC 61010-1, 2nd Edition, 2005-07-22 (Electrical Equipment for Measurement, Control, and Laboratory Use; Part 1: General Requirements) • UL file number: E343390 • CAN/CSA-22.2 No. 61010-1, 2nd Edition, 2004-07, (Electrical Equipment for Measurement, Control, and Laboratory Use; Part 1: General Requirements) • CE: UL / IEC 61010-1; IEC / EN 61000-4; ISO 9001:2008

2.0 INSTALLATION

NOTE: If any damage to the instrument is found, please notify an Arjay Engineering representative as soon as possible prior to installation.

2.1 Controller Installation

Choose the mounting location in accordance with good instrument practice. Extremes of ambient temperature and vibration should be avoided (see specifications and installation drawing).

The 2852-FCS controller may be mounted up to one kilometer from the PMC card using a minimum 18 gauge, 2-wire SHIELDED cable.

Check the polarity of the + and - wiring between the controller and the PMC prior to powering on the unit; + to + and - to - to avoid damage. Shield of cable should be connected to secondary ground terminal marked as \perp . Incoming Earth ground should be connected to primary ground terminal marked \oplus on sub plate.

Important Note: The controller is factory set in a Failsafe mode. This means that the relays are in an energized state during normal operation. The N.O. relay contact will be held closed and the N.C. relay contact will be held open during a normal condition. This will allow the relay to return to its non-energized (shelf) state during an alarm, fault or power failure condition. Wire accordingly.

Note: Maximum Conduit size for installation size is $\frac{3}{4}$ " FNPT.

2.1.1 Permanent Power Connection (AC Powered Models only)

- 1) Connection to the building wiring system shall be in accordance with the Canadian Electrical Code (CEC), Part 1 in Canada, the National Electrical Code, ANSI/NFPA 70 in the USA, or the local electrical codes of the country where the equipment is being installed.
- 2) A disconnecting device is required. The disconnecting means shall disconnect all current-carrying conductors.
- 3) 15A circuit breaker or equivalent fuse is required.
- 4) An external switch or breaker shall be in close proximity to the equipment and within easy reach of the operator. The switch shall be marked as the disconnecting device for the equipment and include the symbols to its "ON" and "OFF" positions using the following symbols:



Power Off



Power On

- 5) The wiring for AC power should be minimum 18 AWG / 300V or as required by local / country codes.
- 6) After field wiring, the primary wires must be secured to the enclosure by tie-wraps to maintain the separation from the signal wires.
- 7) Wiring diagram for permanent connection: See drawings at the back of this manual.
- 8) Use copper conductors only.

2.2 Probe Installation

The probe length is custom ordered to the tank or vessel requirements. On vertical and angled installations, the probe must be long enough to reach the lowest alarm setpoint.

The PMC junction box should be mounted above any risk of flooding.

It is recommended to use a flange, union, or retraction device for easy retraction of the probe from the vessel. This will also assist for routine testing and calibration.

Standard probe entry into a tank is via a 3/4" NPT opening (standard probes) or 1" NPT opening (heavy duty probes). Flanges and concentric shields are available as options. The entrance configuration may vary depending on the application requirements.

TO SCREW IN THE PROBE (THREADED ENTRY), USE A WRENCH ON THE LOWER FITTING ONLY. The probe fittings are compression type with Teflon ferrules assembled by applying torque between the two hex sections. The fittings are sealed at the factory to provide a compression seal capable of withstanding high pressures. Once opened they cannot be reassembled without new ferrules.

The probe orientation can be vertical, horizontal, or angled. The following points are important when installing the probe:

- 1- **Reference ground:** This is important for accurate measurements when foam alarm points are set along the length of a probe, as opposed to basic high alarms. The ground is typically the metal walls of the tank. For non-metal tanks, a ground reference may be necessary to ensure stable accuracy.
- 2- **The distance between the probe and the ground reference:** This only applies to probes without concentric shields. The closer the distance to the tank wall, the greater the sensitivity of measurement; too close and bridging problems may occur.
- 3- **The measurement accuracy may be affected by the temperature change of the material in the tank.** The amount of measurement error depends on the material. If the temperature change is excessive, temperature correction may be required. Contact the Arjay representative for more information.
- 4- **Agitators or moving objects in the tank:** Moving objects in the tank close to the probe such as agitator blades, moving baffles etc. appear as moving ground references to a capacitance probe and will cause measurement errors. In applications where these objects are present, a concentrically shielded probe should be used.

CAUTION: INSTALL THE PROBE WITH CARE: THE TEFLON SHEATH IS USED TO ELECTRICALLY ISOLATE THE METAL PROBE FROM THE LIQUID. DAMAGE CAUSING LEAKS MAY CAUSE READING ERRORS.

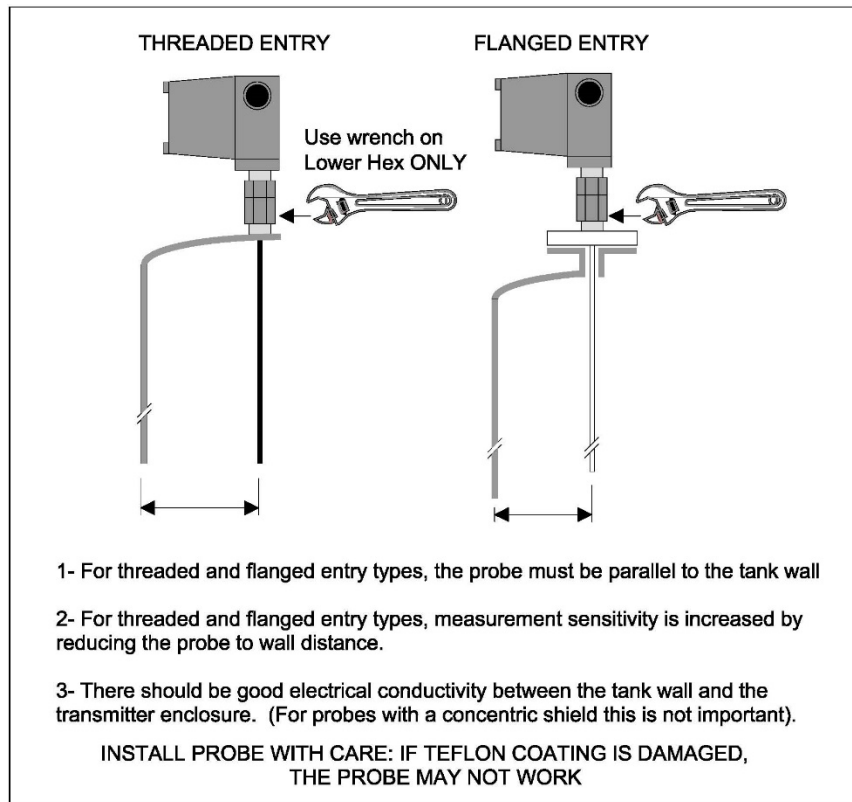

Figure 1 – Probe Installation

NOTE:

To ensure proper operation and electrical safety, make sure the 2852 enclosure and the PMC junction box are electrically grounded.

If the equipment is used in a manner not specified by the manufacturer, the protection provided by the equipment may be impaired.

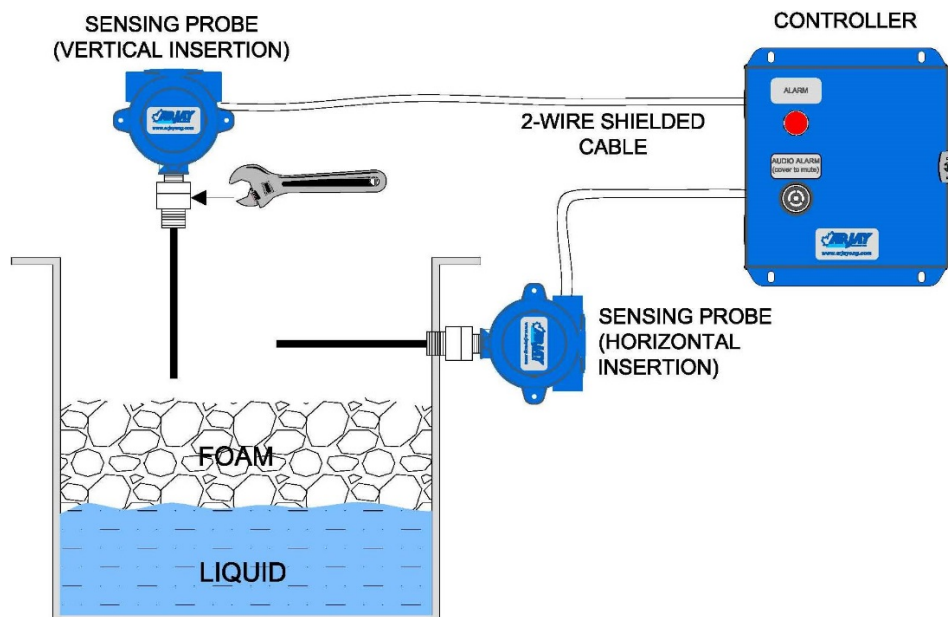

Figure 2 – Typical Application

2.3 Electrical Installation

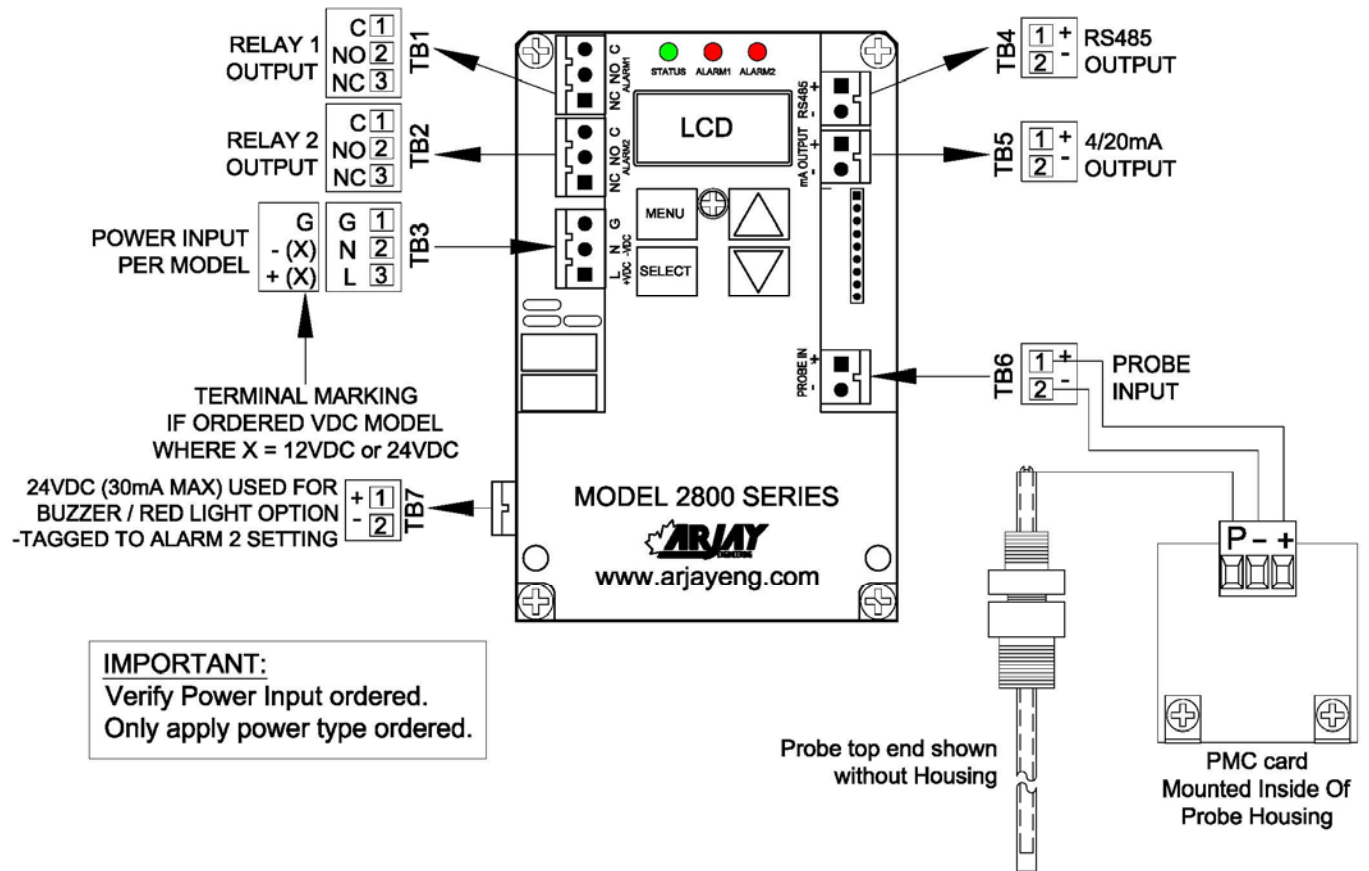

Figure 3 – Electrical Installation Overview

TB1/TB2 - Relay Output

2 SPDT relay, Dry, N.O. Contact 5A @ 250 VAC (Resistive) and N.C. Contact 3A @ 250VAC (Resistive), selectable failsafe or non-failsafe, selectable high or low acting alarm, programmable time delay: 0 – 600 seconds

TB3 - Power Input

Power input as per Model. Check if ordered AC or DC. . Earth ground is connected to G.

TB4 - Network Output

Connect RS485 + and – to the network D+ and D-.

TB5 - 4/20 mA Output (+ and -)

The 4/20 mA is a sourced output referenced to Ground. It is not loop powered.
4mA = Normal 20mA = Alarm

TB6 - Probe Input

Connect '+' to '+', '-' to '-' between the controller and the PMC card. Check polarity to avoid damage.

TB7 – Buzzer / Red Pilot Light Output (Optional)

The connection will be factory wired if ordered.

2.3.1 Input / Output Terminal Specification

Input Terminals – Power Source					
Terminal ID	Overvoltage category	Rated Voltage (V)	Rated Current/power (A/W/VA)	___ HZ or DC	Specified Mains fluctuation
TB3	II	100-240V	150mA	50/60Hz	± 10%
TB3	II	12 OR 24V	250mA	DC	+15% -10%







Input Terminals – Measuring Circuits					
Terminal ID	Function	Measurement Category	Nominal a.c. or d.c line to neutral voltage / if CAT I, Max. transient overvoltage Ut	Nominal a.c. or d.c current	Rating of insulation required for external circuit
TB6	Frequency	I	15V, 50mA / 0	--	DI * or RI**
TB4	RS485 Communication	I	5V, 5mA / 0	--	DI * or RI**

* Double Insulation

**Reinforced Insulation

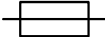
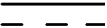
Output Terminals					
Terminal ID	Function	Isolation or protection	Rated V, A	Max. V, A	Load type and nominal
TB1	Load	Relay	N.O. Contact 5A @250VAC & N.C. Contact 3A @250VAC	--	--
TB2	Load	Relay	N.O. Contact 5A @250VAC & N.C. Contact 3A @250VAC	--	--
TB5	Current	Isolator(optional)	- 18V, 20mA, 900Ω - 9V, 20mA, 450Ω	50mA @18V	--
TB7	Voltage	None	24VDC, 30mA	--	Buzzer / Pilot Light

2.4 Glossary of Symbols

	Attention, consult accompanying documents Attention, veuillez consulter les documents ci-joints.		
	Protective Earth Terre de protection		Fuse Coupe-circuit; fusible
	Direct Current (DC) Courant continu		Normally open relay contacts Contacts travail
	Normally closed relay contacts Contacts Repos		Power off Arrô (mise hors tension)
	Power on Marche (mise sous tension)	L	Live Sous tension
N	Neutral Neutre	G	Ground Terre

3.0 STARTUP AND CALIBRATION

3.1 Startup

Check that the power wiring and PMC wiring are wired in accordance with the electrical installation drawing.

Power On the unit. Allow a 1 hour warm-up period before calibrating.

The Status LED on the controller circuit board should be green. A red Status LED indicates a fault condition. If red, check the Troubleshooting section.

The unit is pre-configured and tested at the factory. However, a quick field calibration is required after power up to tune the probe to the installation conditions. See section 3.3 to calibrate the 2852-FCS.

3.2 Menu Flow Chart Background Information

The control setup, diagnostics, and calibration are accessed using the display and keypad on the controller. The Flow Chart in Section 7.0 provides an overview to the various menus and features. Keep a copy of the flow chart at hand when accessing the internal controller features.

Below is a description of the menu functions.

3.2.1 Menu Description

Since the 2852 controller has a small LCD, some menu descriptions may be in short form. The following are the menu descriptions:

<i>Diags:</i>	<i>Diagnostics</i>	<i>SENSTVTY:</i>	<i>Sensitivity</i>
<i>Cal Pts:</i>	<i>Calibration points</i>	<i>A1:</i>	<i>Alarm relay 1</i>
<i>Auto Cal:</i>	<i>Auto calibrate</i>	<i>A2:</i>	<i>Alarm relay 2</i>
<i>Man Cal:</i>	<i>Manual calibrate</i>	<i>Alrm:</i>	<i>Alarm</i>
<i>Cal Ok:</i>	<i>Calibrate ok</i>	<i>Alrm Lvl:</i>	<i>Alarm level</i>
<i>Cal Err:</i>	<i>Calibrate err</i>	<i>Diff Hi:</i>	<i>Differential Hi alarm set value</i>
<i>mA out:</i>	<i>mA output</i>	<i>Diff Lo:</i>	<i>Differential Lo alarm set value</i>
<i>mA Span:</i>	<i>mA output span</i>	<i>Alrm Del:</i>	<i>Alarm Delay</i>
<i>Sec:</i>	<i>Seconds</i>	<i>^SP:</i>	<i>Relay Setpoint Hi action</i>
<i>ALRM CAL:</i>	<i>Alarm Calibration</i>	<i>vSP:</i>	<i>Relay Setpoint Low action</i>
<i>Cal:</i>	<i>Calibration point</i>		

3.2.2 Menu Description

The 2852 controller will display **Normal** in its normal operating condition and **A1** or **A2** for an Alarm condition of Relay 1 or Relay 2.

From the main menu, you can select **Cal Only, View, and Change**.

Cal Only allows a user to calibrate after the equipment is installed. The calibration is required at site after power up or anytime a component or sensor is changed out. A password is required to enter this and is described in the calibration section.

View allows an operator to view the **Calibration** setpoints in pF, the **Alarms** settings (2852 only) such as low or high action, failsafe or non-failsafe and the 0-600 second delay, the **Diagnostics** of raw readings and the **Setup** values such as mA output and ID address. This can be viewed without a password and without risk of changing any values. This information may be requested during technical assistance inquiries.

Change is password protected and allows an operator to enter or change the configuration set-up values indicated in the View. Changes will be required for the initial setup of relay setpoints, delays, span etc. or to re-set the values to the factory default.

3.2.3 Data Entry

Data Entry

Press <▲> / <▼> key to increase / decrease the digital value.

Press <SELECT> key to move the cursor.

Press <MENU> key to abort certain screens

3.3 2852 Controller Calibration

Power up the 2852 Controller. The status LED should be green. The LCD will scroll to the normal operating screen after a series of the following screens (each display for 2 sec.). It may read **Normal** or **A1 A2** until a calibration is performed.

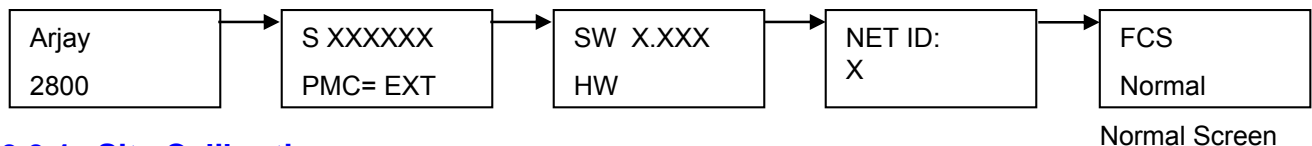

3.3.1 Site Calibration

For a single point high foam alarm, the foam level may not need to be changed.

For a high alarm application, a *vertical or horizontal* probe can be in air and well above the liquid or foam. The probe is calibrated to air and as the foam reaches the probe, it will alarm.

For a low alarm application, a *horizontal* probe can be fully submerged in foam during calibration. The probe is calibrated to the foam and as the foam interface drops below the probe, it will alarm.

However, on vertical probes, if the alarm setpoint is desired at a specific point along the length of the probe, or if the differential control is being used, a foam level change during calibration will be required. If a second HI alarm is required then the foam will also need to rise to this desired level. The buzzer and light options are tagged to the 2nd Alarm point.

The following are the basic steps for setting up two alarm points each with a HI/LO differential. Refer to the Flow Chart for a detailed set-up and calibration.

Check that the foam or liquid is at the desired level for calibration (ie. that the probe is in air for a typical high level alarm application).

Press and hold Menu key for 5 seconds to enter the main menu. The display will read the first menu item **Cal only**. Press select key, enter password "2000".

The display will read **Select Cal A1**. Press Select to calibrate the first setpoint of Relay 1. This can be either the HI or LOW point of the differential.

This display will read **A1 PT 1** with a pF reading of the probe displayed. Press select to acknowledge and then press select to confirm the new calibration.

The display will read **A1 PT 2** with a pF reading. This is the second point for Relay 1. For a single point alarm without differential this will be the same point. Press select to accept this second point. If differential control on the relay is required, change the foam level to the new setpoint level and press Select.

The menu will now guide you through setting up the second relay (A2) setpoints. If a buzzer or light was supplied with the unit, they will activate at the Alarm 2 setting. If your application is to have all alarms active at the same point, calibrate Alarm 2 as you did for A1. If you require Alarm 2 to be at a higher setpoint level, you will need force the foam level up to the desired alarm point on the probe before calibrating Alarm 2. This second point may be required in case the foam continues to rise due to a defoamer failure or lack of chemicals.

When complete, Select **EXIT**.

This will get you back to the main menu of "CAL ONLY". Press arrow down until you get to "EXIT" in order to get back to main screen OR go to "Change" if different relay configurations are required.

**THIS COMPLETES THE SETUP AND CALIBRATION PROCEDURE FOR THE
2852-FCS Foam Control Switch**

4.0 SETUP AND ALARM

4.1 2852 Controller Setup

The 2852 controller has the following Setup parameters:

1. Sensitivity

The sensitivity determines the amount of pF change required to cause an alarm. The factory default setting is 1.0 pF. The most sensitive setting is 0.1 pF. Increasing the pF value will increase the amount of foam required to cause an alarm. Since different foams have different dielectrics, a pF to mm of foam relationship cannot be factory determined. If this is changed in the field, it should be tested to confirm an alarm.

2. Alarm Calibration above or below setpoint

This setting advises the controller if the calibration setpoint is above or below the alarm condition. For high alarm applications, the alarm condition is above calibration setpoint. This indicates that the pF value must increase above the setpoint to activate the alarm. For low alarm applications, the alarm condition is below the calibration setpoint. This indicates that the pF value must decrease below the setpoint to activate the alarm. The factory default is Alarm = ^SP

3. Defaults

Factory settings are pre-configured into the unit based on the most typical set-up required for this application. This provides for a quick and easy calibration at site but can be changed for special applications. If the setup has been changed, this will change back to the factory defaults.

4. Net ID

The ID number is used only for network applications. To communicate on a network, each controller must have a unique ID number. The factory default ID number is 1.
Important: If multiple units on a network have the same address, network errors will result.

5. Filter

Data filtering is used to smooth data from a sudden change and minimize fluctuating readings. For example, a 5 second setting means the calculated value of the capacitance and resulting values of pF will start to respond immediately but will take 5 seconds to reach their final values. The factory default is 0 to provide an immediate and active response.

4.2 2852 Controller Alarms

The two relays on the 2852-FCS operate independently. They are named A1 and A2. The follow parameters are available to set up each of the relays.

1. Delay. Minimum time in seconds for an alarm to exist before the relays change to an alarm state. The relay alarm state depends on the Relay Action and Failsafe settings. The factory setting is 0 seconds.
2. Action. This determines if the Alarms LEDs should activate when the pF reading rises above or below the setpoint. The factory default is above the setpoint because the application of air to foam is an increase in capacitance.
3. Failsafe. Failsafe typically means that the relay is held in an energized state when in a normal operating condition as opposed to an alarm condition. In an alarm condition, the relay de-energizes which is identical to when the instrument power is shut off. The rationale is that the alarm condition should match the Power Fail condition. The factory default is Yes for Failsafe.

Example Of Single Point Alarms (No Differential) Applications

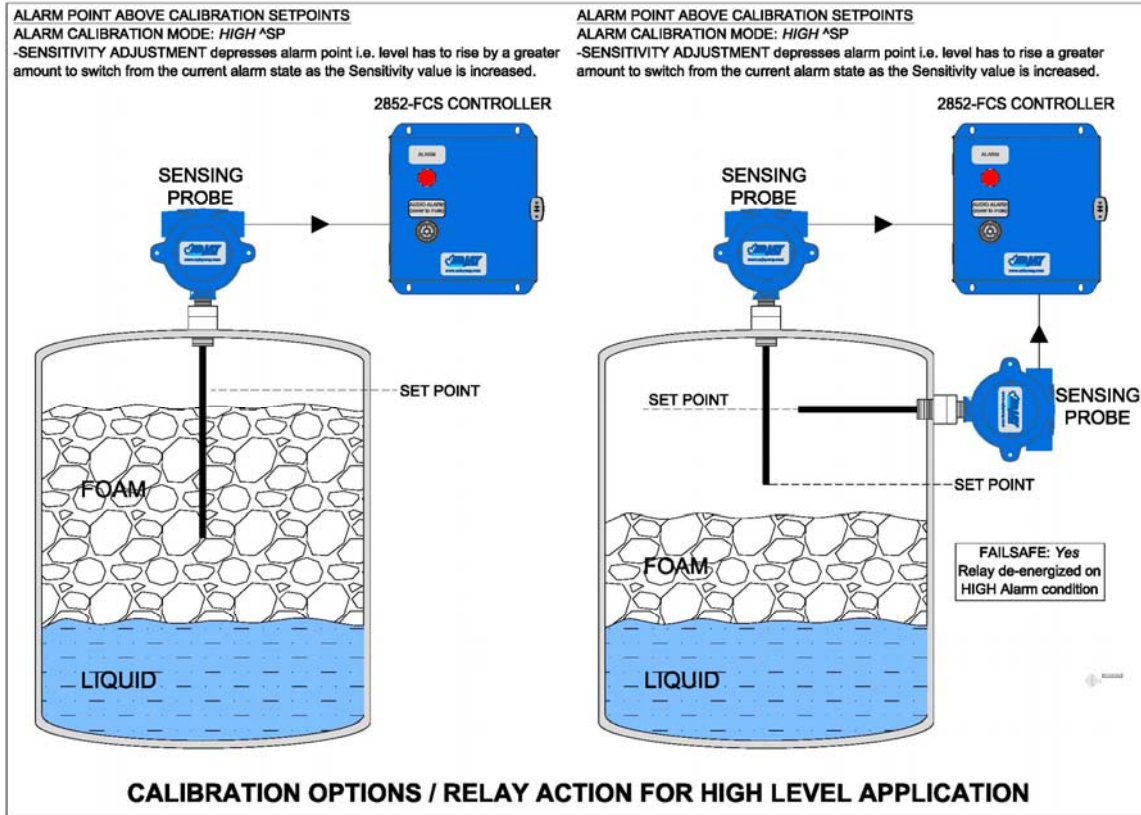

Figure 4 – No Differential Application – High Level

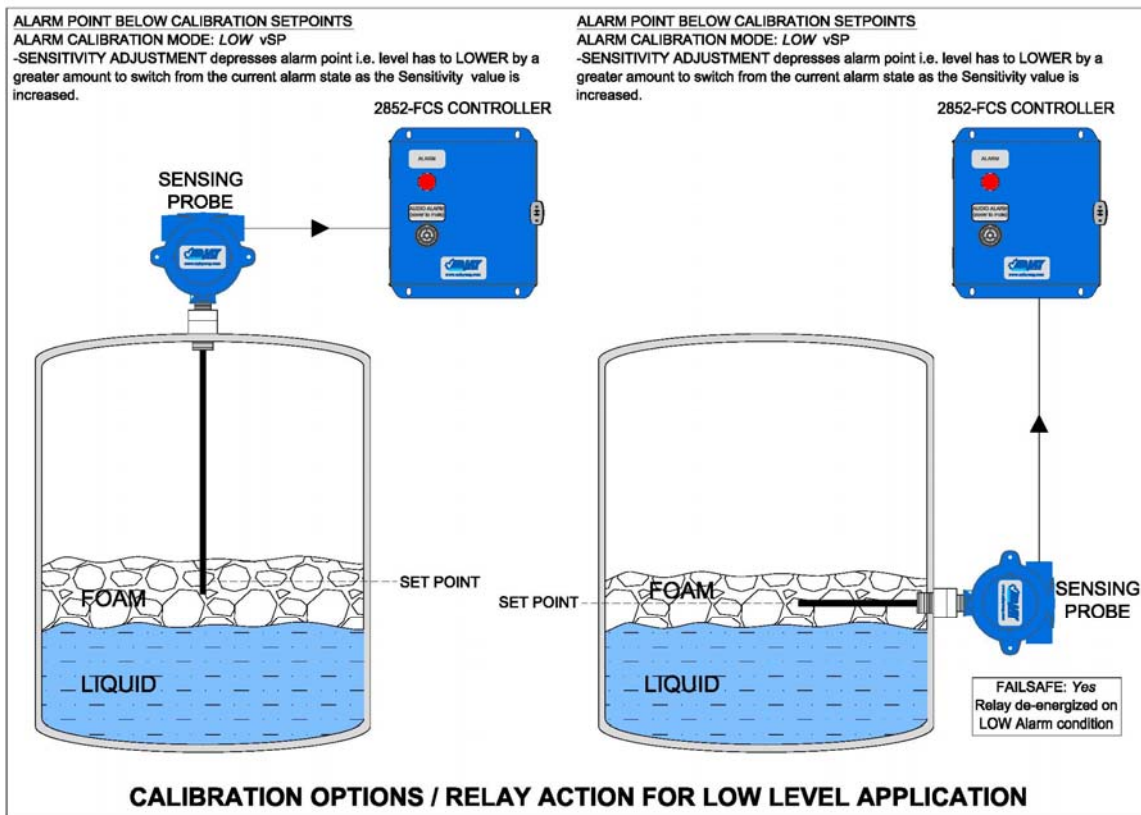

Figure 5 – No Differential Application – Low Level

4.3 2852 Controller Network

The 2852 Controller may be monitored and calibrated via RS-485 protocol compatible digital communications.

Typical features are:

1. Ease of wiring in multiple level point monitoring:

Up to 255 Model 2852's (or other Arjay 2800 Series level monitors) may be connected together in a daisy chain (2 wire communication plus power wiring) connection to an Arjay Remote Access monitor or customer control system which allows viewing data and setup of any of the transmitters on the network. The relay and analog outputs may still be used if necessary.

2. Setup for the 2852 for network operation:

Each 2852 transmitter must have a unique ID number to connect in a network system.

4.3.1 Modbus Configuration

Parameter settings: 9600 Baud Rate; Even Parity, 8 Data Bits and 1 Stop Bit.

Wiring connection: RS485 (+) connect to D+; RS485 (-) connect to D-.

4.3.2 2800 Series Modbus Register Mapping

REG	Zero Based	DESCRIPTION	TYPE	No. of Reg
40001	0	Serial Number	float	2
40003	2	Hardware Rev / Software Rev	byte	1
40004	3	Sensitivity / Mode	byte	1
40005	4	Instrument Status	int	1
40006	5	Model / Modbus Address	byte	1
40007	6	Relay2 Setup / Relay 1 Setup	byte	1
40008	7	Password	int	1
40009	8	XA "A" cal parameter	float	2
40011	10	XK "K" cal parameter	float	2
40013	12	XC "C" cal parameter	float	2
40015	14	Filter	float	2
40017	16	Slope – pF per % level	float	2
40019	18	Offset – pF for empty vessel	float	2
40021	20	mA output span value	float	2
40023	22	mA output Zero value	float	2
40025	24	mA output Trim Slope value	float	2
40027	26	mA output Trim Offset vlaue	float	2
40029	28	Cal1 PV: 1st calibration point level value in %	float	2
40031	30	Cal2 PV: 2nd calibration point level value in %	float	2
40033	32	Cal1 pF: 1st calibration point capacitance value in pF	float	2
40035	34	Cal2 pF: 2nd calibration point capacitance value in pF	float	2
40037	36	Relay 1 : Differential High Alarm [% Level]. Only used for Linear Level type. Not used for Single Point Alarm application	float	2
40039	38	Relay 2: Differential High Alarm [% Level]. Only used for Linear Level type. Not used for Single Point Alarm application	float	2
40041	40	Relay 1: Differential Low Alarm [% Level] OR Single Point Alarm [pF]. Single Point Cal: used as captured pF during cal	float	2
40043	42	Relay 2: Differential Low Alarm [%Level]. Only used for Linear Level type. Not used for Single Point Alarm application	float	2
40045	44	Relay 1 On delay [in seconds]. Only used for Linear Level or Single Point Alarm application	int	1
40046	45	Relay 2 On delay [in seconds]. Only used for Linear Level type. Not used for Single Point Alarm application	int	1
40047	46	mA Analog Output	float	2
40049	48	Oscillation Frequency	float	2
40051	50	Frequency	float	2
40053	52	Capacitance	float	2
40055	54	Filtered Capacitance	float	2
40057	56	Level	float	2

5.0 MAINTENANCE

There is no routine cleaning required for this controller.

6.0 TROUBLESHOOTING

CONDITION	DO THIS
1. Status LED is OFF and the LCD display is off	Check the power to the unit. If the unit is a 12VDC or 24VDC model, check the external source and polarity is correct. If the unit is a 100-240VAC model, then check the Line, Neutral and Ground wiring is correct.
2. If the status LED is RED	<p>This indicates a major error such as memory failure, no probe signal etc. Check the following:</p> <ul style="list-style-type: none"> • Make sure the PMC is installed • Make sure the PMC wiring is correct and there are no breaks in the wiring. At the controller, measure across the Probe Input terminals with a DC meter. Make sure "Common" lead of meter is on '-' terminal. It should read (+) 8 to (+)10 VDC with the PMC connected and approximately 20 to 24 VDC with the PMC terminal disconnected. • Microprocessor may have lost its parameters due to a surge in the line. Go to Diagnostic Menu (see Flow Chart) to check the Calibration values, frequency and capacitance values • Call Arjay Technical Support.
3. No mA output OR incorrect mA output.	<p>IMPORTANT: THE UNIT SOURCES mA OUT FROM THE mA OUTPUT TERMINAL. <u>THIS TERMINAL SHOULD NOT BE CONNECTED TO +24V.</u> IT IS NOT A 2 WIRE mA TRANSMITTER. See Figure 4 for Electrical hookup details.</p> <ul style="list-style-type: none"> • Disconnect external wires from mA output and measure with mA Meter. • Check the mA output Action (direct or inverse) and mA output Span are set as desired. See section 6.0 Flow chart / Change menu. • If the mA output still does not match the level, then call Arjay Technical Support.
4. False Alarms	<ul style="list-style-type: none"> • Add some time delay in the unit • Make sure there is no external interference and electrical noise such as agitators, high voltage interference, turbulent flow, etc • Adjust the sensitivity to the next higher value. Test after any changes to confirm an alarm

ARJAY ENGINEERING TECHNICAL SUPPORT

(800) 387-9487

+1 (905) 829-2418

www.arjayeng.com

7.0 FLOW CHARTS

NORMAL OPERATING DISPLAY

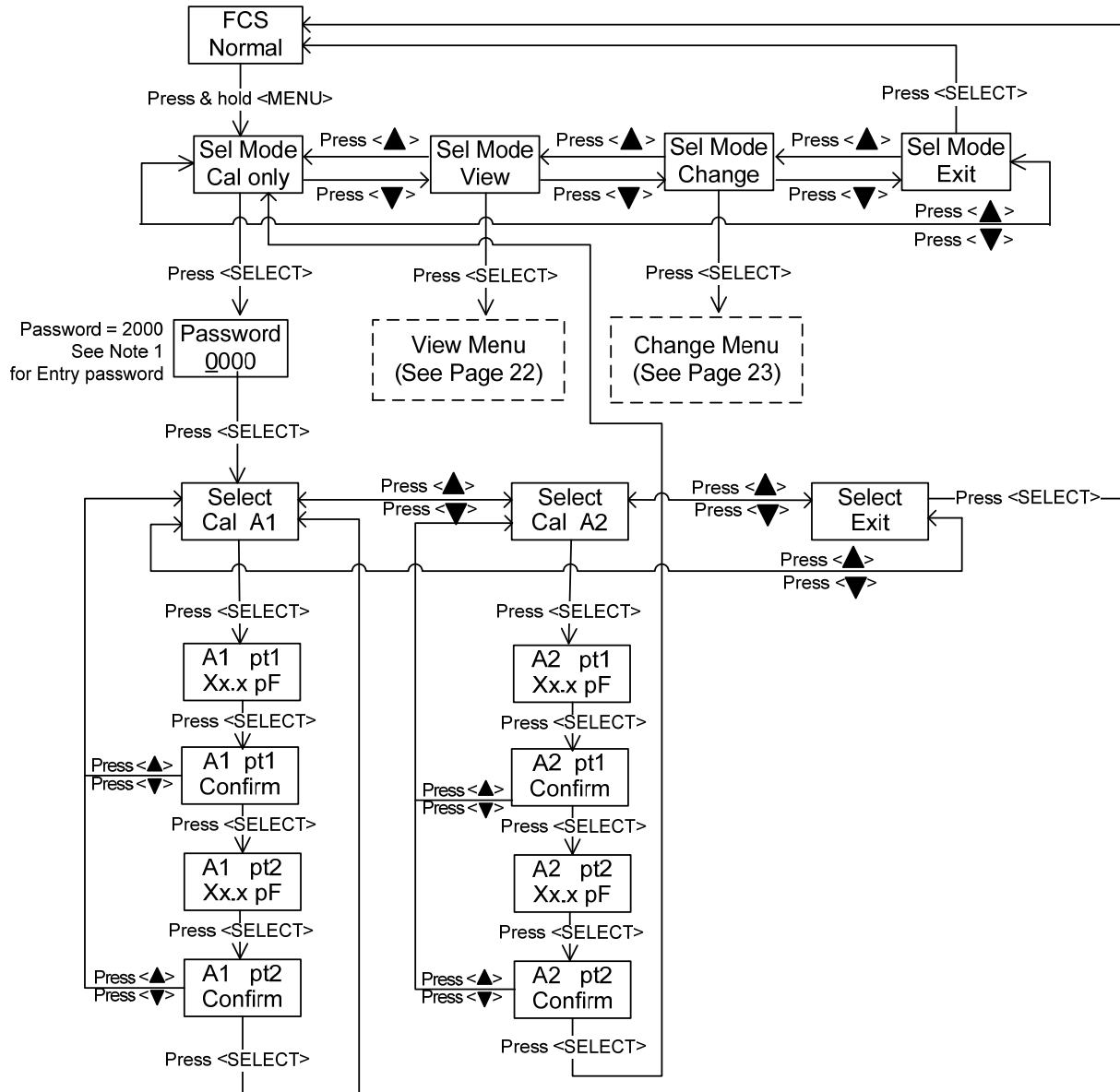

Note 1: Data Entry

_: Flash cursor indicates to entry the value
 Press <▲> / <▼> key to increase / decrease the digital value.
 Press <SELECT> key to move the cursor.

Note 2: Calibration Confirm

Press <Select> to accept the calibration value.
 Press <▲> / <▼> key to discard the calibration value.

VIEW MENU

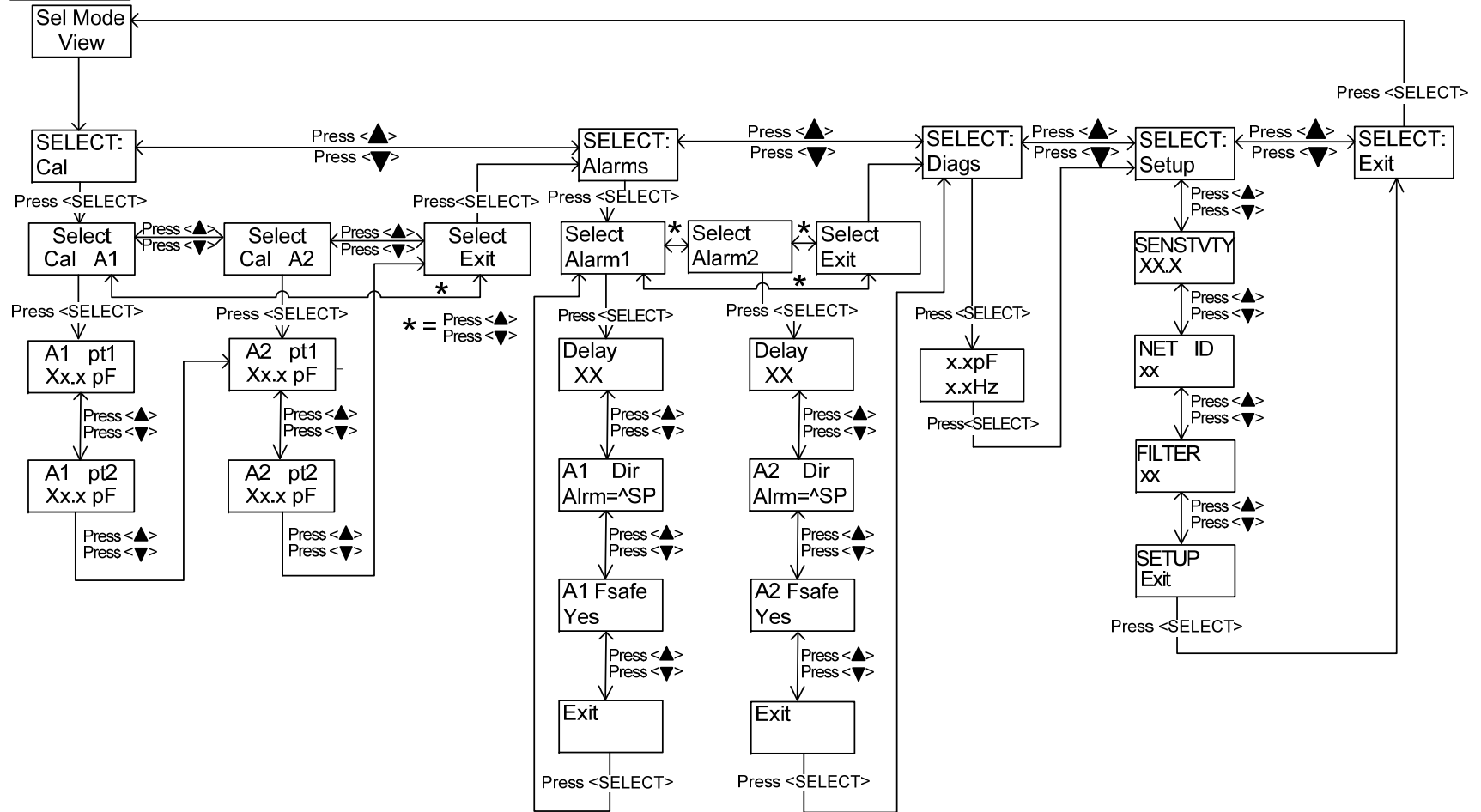

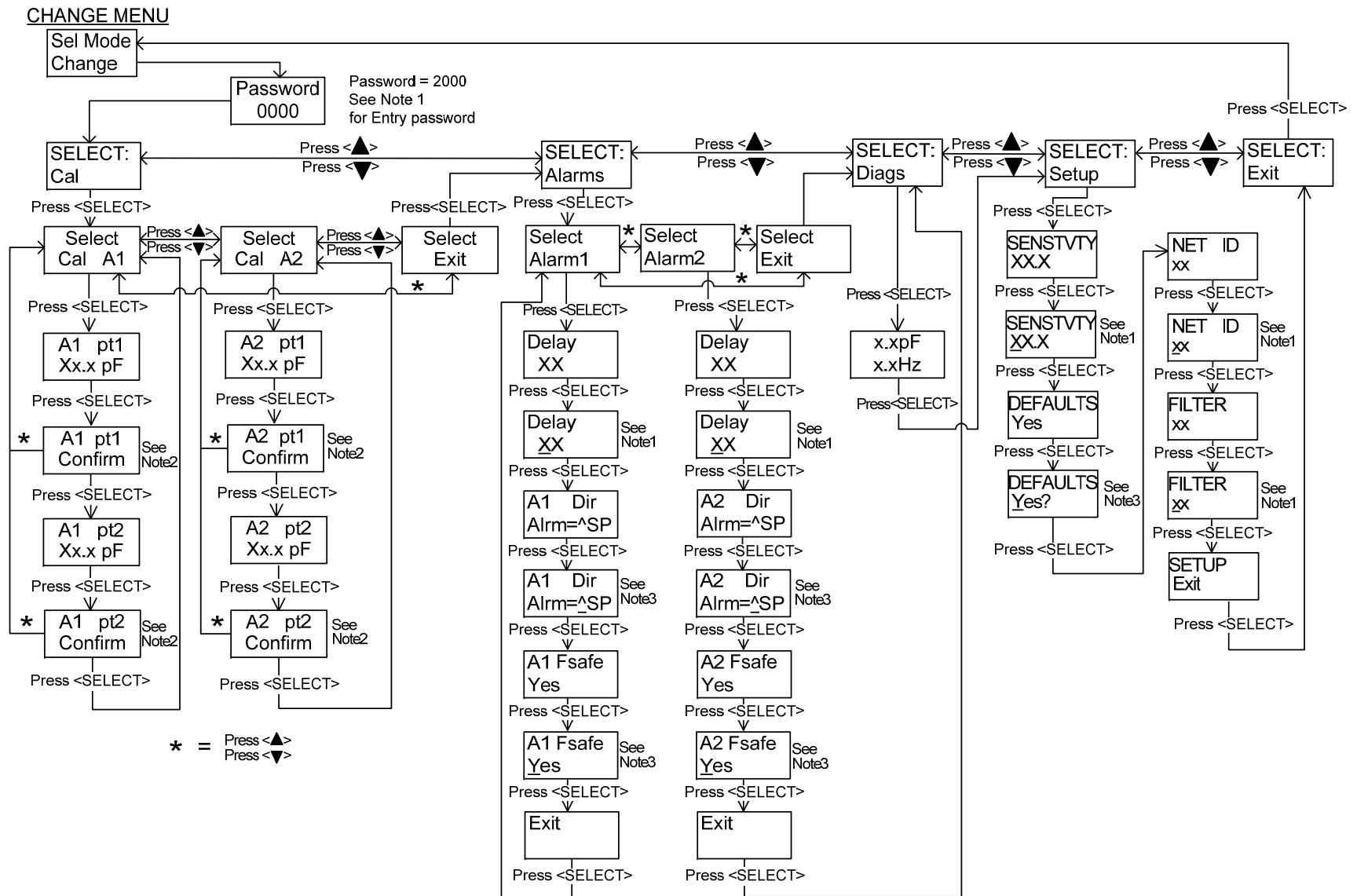

Note 1: Data Entry

: Flash cursor indicates to entry the value
 Press <▲> / <▼> key to increase / decrease the digital value.
 Press <SELECT> key to move the cursor.

Note 2: Calibration Confirm

Press <Select> to accept the calibration value.
 Press <▲> / <▼> key to discard the calibration value.

Note 3: Value Selection

: Flash cursor indicates to select the value
 Press <▲> / <▼> key to select the desired value.